



FIBER SERIAL SIGNAL CONVERTER TO
RS485 – CFRS

CATALOG

INDEX

INDEX.....	1
INTRODUCTION.....	2
KEY FEATURES.....	2
DIMENSIONS.....	3
CONNECTION DIAGRAM	3
APPLICATION EXAMPLE	4

INTRODUCTION

The **CFRS** is a converter designed to integrate industrial communication networks, allowing the conversion of the **optical fiber signal to RS-485**. This equipment is essential for applications that require long-distance data transmission, high speed, and immunity to electromagnetic interference.

Used in automation, control, and monitoring systems, CFRS enables the secure interconnection of RS-485 devices in industrial environments and other sensitive applications. Compatible with all communication protocols that follow RS-485 standards (ANSI/TIA/EIA-485-A two-wire), and also optical fiber, which makes the network completely immune to electrical noise, electromagnetic interference, lightning strikes, and voltage surges, increasing the reliability of data traffic, communication speed and distances between IEDs / data server or supervisory system (Scada).

CFRS was built in compliance with strict quality standards and uses state-of-the-art electronic components (SMD), its hardware was designed to withstand severe working conditions, and can be installed directly in power substation panels. Complies with the requirements of IEC, DIN, IEEE, and ABNT standards for performance, durability, and reliability.

MAIN CHARACTERISTICS

- Compact housing with 22.5x100x113.5 mm in ABS for DIN rail 35 mm;
- Communication speed from 1200 to 115200 bps;
- Maximum fiber length of 3000 m (multimode optical fiber, 62.5/125 μm);
- Fiber connector in ST standard;
- Minimum transmit power -14.0 dBm (multimode optical fiber, 62.5/125 μm);
- Maximum transmit power -10.0 dBm (multimode optical fiber, 62.5/125 μm);
- Minimum receive sensitivity -24 dBm (multimode optical fiber, 62.5/125 μm);
- Supports 50/125 μm , 62.5/125 μm , 100/140 μm , and 200 μm multimode optical fiber;
- Wavelength 850 nm;
- Indication with LEDs of on, transmission and reception of data and link;
- Transmission Mode: Half Duplex;
- Resistant to lightning strikes and damage caused by electrostatic discharge;
- Resistant to EMI/RFI and current surges, ideal for data communications near transformers, heavy electrical equipment, and other electrical or radio interference;
- Easy installation and use.
- 2 years warranty.

DIMENSIONS

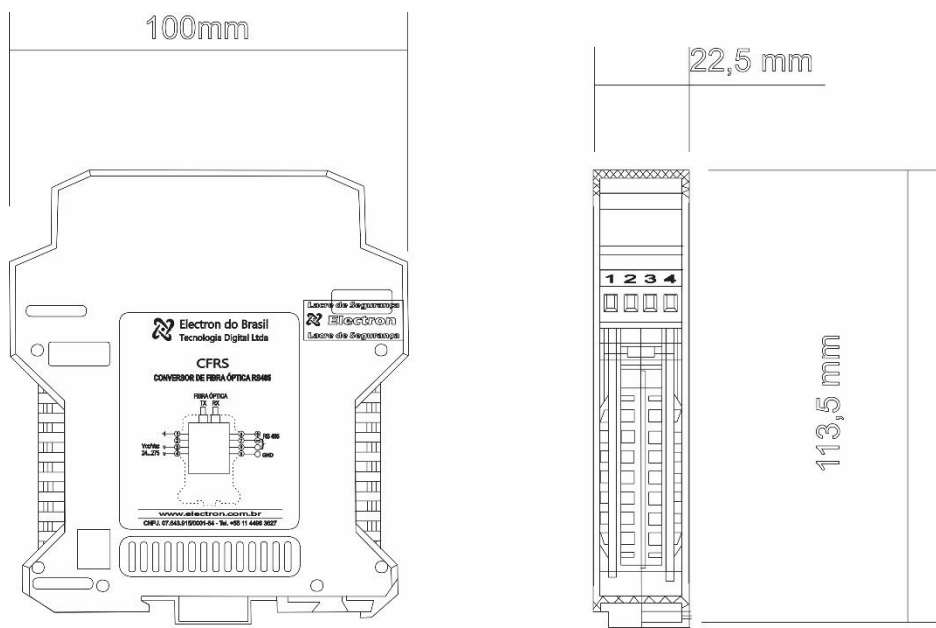

CONNECTION DIAGRAM

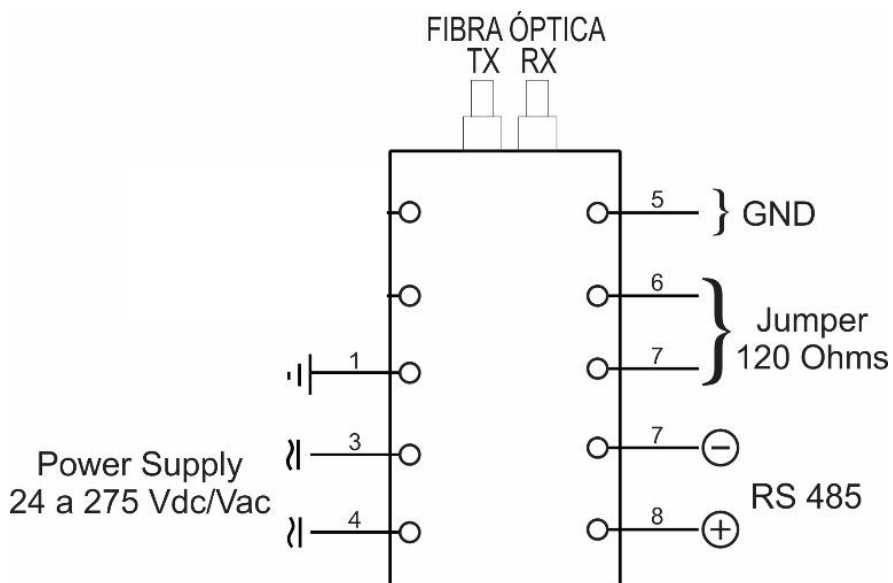

APPLICATION EXAMPLE

