



DVR – VOLTAGE REGULATOR RELAY

Manual

INDEX

INDEX	2
INTRODUCTION	3
KEY FEATURES.....	4
TECHNICAL DATA	5
TYPE TRIALS MET	6
APPLICATION EXAMPLE.....	6
DIMENSIONS.....	7
CONNECTION DIAGRAM	8
SPECIFICATION FOR ORDER.....	11
GETTING TO KNOW THE DVR	12
DISPLAY CONFIGURATION.....	13
SWITCH COMMAND MENU.....	14
MENU RESET.....	15
CONSULTATION MENU	16
SETUP MENU	19
MENU PROTECTION	28
MENU ADJUSTMENT.....	30
MENU TRAFO.....	38
MENU SWITCHING.....	39
MAINTENANCE MENU	43
MENU PARALLELISM.....	46
IMPORTANT RECOMMENDATIONS	48
IMPORTANT RECOMMENDATIONS CABLING	48
WARRANTY TERM.....	49
Disclaimer of Warranty:.....	49
Loss of Warranty:	49
Use of the Warranty:.....	49

INTRODUCTION

Or **Digital Voltage Regulator Relay - DVR** it is designed to automatically monitor and regulate the voltage of changers under load from up to 51 TAP positions (ANSI 90); measure and display the deviation from the reference voltage; and control, through commands on the switch, the mains line voltage considering the compensations according to the previously programmed load profiles with up to 8 sets of different values with input by pre-established time or by external command.

As a reference, the **DVR** Can:

- Monitor up to 3 TP's (3 phases);
- Measure the flow of electric current up to 3 TC's (3 phases);
- Measure and indicate the position of the current, maximum, minimum and previous TAP;
- Indicate the Active, Reactive and Apparent Powers;
- Calculate the Power Factor ($\cos \phi$) of each phase measured with lag between TP and CT from 0° to 330° with automatic recognition and calculation;
- To act the interlock protection of the switch when there is overcurrent, overvoltage, undervoltage and inversion of the flow of electric current;
- Monitor the amount of switching and wear of the switchgear contacts by interrupted current and number of switching with the switchgear monitoring function;

The DVR Hardware uses state-of-the-art SMD type electronic components with reduced sizes of up to 0.04"x0.02" that are inserted into the boards with an automatic Pick'n Place machine with laser alignment, in order to ensure the quality of the assemblies, the boards are inspected by automatic cameras (**AIO**) without human interference to ensure that all technology implemented in the product has the best performance for the user for a long time. much longer life span. The main components are military grade for use in extreme application conditions, withstanding severe working conditions, they can be installed directly in the power transformer panel or reactors in panels in the yard of power substations (-20°C to 70°C), offshore platforms, chemical industries (resin and protected plates) or even places subject to seismic shocks. All these benefits used are the result of many years of experience and research. Our designs meet the levels of demand, supportability and reliability according to the most demanding standards in the world: **IEC, DIN, IEEE and ABNT.**

KEY FEATURES

- **OLED display** with a graphic capacity of 128 x 61 pixels, with contrast adjustment and inversion of background colors and letters, readable in any lighting condition, including directly exposed to the sun;
- Supply voltage from ± 48 to 260 Vdc or Vac 50/60Hz;
- Operating temperature from -20°C to 70°C;
- Storage temperature from -50°C to 40°C;
- Multimeter function, voltage indication (Vca) of the 3 phases on the screen, current indication (AC) of the 3 phases, percentage deviation and value of the reference voltage, active, reactive and apparent power of the 3 phases, transformer load percentage, power factor ($\cos \phi$) and frequency of the 3 phases;
- Adjustable TP/CT lag from 0 to 330°, allowing TP and CT connections in different phases or in the 3 phases;
- 3 current inputs that use Split-Core sectionable CTs to measure up to 10 Amperes (AC);
- 1 resistive input (3 wires) for up to 5K Ohms or analog from 4 to 20 mA for indication of up to 51 TAP positions with automatic potentiometric crown pitch recognition;
- Front Micro USB for parameterization via UseEasy™ software;
- 1 RS-485 Digital Output (**ANSI/TIA/EIA-485-A**) in optical fiber or 2 wires with **MODBUS RTU** and **DNP3** (Level 2) slave Communication Protocol for remote access to all measured parameters;
- Auto Baud Rate from 2,400 to 57,600bps (Automatically Detects the Speed of the Communication Network);
- 1 RS485 Digital Output (**ANSI/TIA/EIA-485-A**) with **Proprietary** protocol (Slave/master) for parallelism management of up to 32 **DVRs** or **IPTP devices**;
- 8 sets of adjustment for line drop compensation by resistance and reactance adjustments or by the simplified voltage drop percentage method, (Z compensation) with programming by time or external command;
- Independent actuation times for raising and lowering voltage, with linear, step-linear, or intense curve timing modes;
- CDC lockout in case of user-configurable overcurrent, reverse current, and undervoltage;
- CDC blockage and/or rapid voltage decrease;
- Automatic switch lock triggered;
- 14 Programmable Relays of 6 Amperes/250 Vac;
- 3 programmable digital inputs (Dry Contact);
- 5 configurable analog outputs that can be from 0 to 1, 0 to 5, 0 to 10, 0 to 20 or 4 to 20 mA;
- Full reading of the resistance of the potentiometric crown and automatic calibration of the number of steps;
- Indication of simple numerical, bilateral numeric and alphanumeric reading;
- Remote commands through wired connections of the digital inputs or **MODBUS RTU** and **DNP3 L2** communication to give the RAISE / LOWER voltage commands or select the regulation set;
- Event warnings on the display with display of the alarm name and the relay that triggered;
- Through the UseEasy™ software, all equipment parameters can be saved in manipulable files that can be reconfigured other equipment;
- 14 LEDs for indication of the performance of the programmable relays with indication on the display of the acting event;
- Watchdog that supervises the integrity of the connection to the potentiometric crown, as well as the change of TAP when the command is sent;
- High mechanical strength housing, built entirely in DIN IEC **61544 standard aluminum**;
- Reduced size 98x98x98xmm;
- 2 years warranty;

TECHNICAL DATA

VOLTAGE REGULATOR RELAY – DVR	
Operating Voltage	48 to 265 Vdc/VAC 50/60Hz;
Operating Temperature	-20°C to +70°C;
Consumption	<15W;
Voltage Measurement Input	3 Phases – 0~280 Vac – 46/64 Hz;
Position measurement input;	From 1~51 positions – Crown up to 5,000 Ohms;
Dry Contacts Input	3 inputs for dry contacts (potential-free);
Input for Electrical Current Measurement	3 Split Core TC's from 0 to 10A;
Analog Output and Maximum Loads Options (5 outputs configurable on the device)	0 ... 1mA – 8000 Ohms;
	0 ... 5mA – 1600 Ohms;
	0 ... 10mA – 800 Ohms;
	0 ... 20mA – 400 Ohms;
	4 ... 20mA – 400 Ohms;
Maximum Error of Measurement Inputs	0.25% of the end of the scale;
Maximum Analog Output Error	0.25% of the end of the scale;
Outgoing Contacts	14 – Potential-free and programmable;
Maximum switching power	40W/250VA;
Maximum Switching Voltage	250 Vac/Vac;
Maximum Driving Current	6.0 A;
Network Serial Communication Port	MODBUS RTU and DNP3 L2 (slave);
Auto Baud Rate and/or Fixed Speed	2,400 to 57,600 bts;
Front USB Port	Micro USB;
Datalogger	Micro SD 8GB v10 for data acquisition;
IEC 61554 DIN Box	98x98x98x mm – Aluminum;
Fixing the equipment	Flush Panel Mounting;
Degree of Protection (NBR IEC 60529)	IP 40 (Front), IP 20 (Connectors);
CURRENT TRANSFORMER – TC SPLITCORE/CLAMP	
Measurement Range	0 to 10 A;
Maximum Error of Measurement Inputs	1% of the end of scale;
Linearity	1% of the end of scale;
Operating Temperature	-40°C to +85°C;
Storage Temperature	-50°C to +60°C;

Table 1 – Technical Data

TYPE TRIALS MET

- Applied Voltage (IEC 60255-5): 2kV / 60Hz / 1 min. (against land);
- Voltage Impulse (IEC 60255-5): 1.2/50 μ sec. / 5kV / 3 sec. and 3 sec. / 5 sec. Interval;
- Electrostatic Discharges (IEC 60255-22-2): Air mode = 8kV / Counted mode = 6 kV;
- Immunity to radiated electromagnetic disturbance (IEC61000-4-3): 80 to 1000 MHz / 10V/m;
- Immunity to Fast Electrical Transients (IEC60255-22-4): Input/Outputs=4kV/common. 2kV;
- Immunity to radiated electromagnetic disturbance (IEC61000-4-3): 80 to 1000MHz/10V/m;
- Immunity to fast electrical transients (IEC60255-22-4): Voltage/Input/Outputs=4kV/common. 2kV;
- Surge Immunity (IEC60255-22-5): phase/neutral 1kV, 5 per polar. (=) – phase-to-ground/neutral-to-ground 2kV, 5 per polar (\pm);
- Immunity to conducted Electromagnetic disturbances (IEC61000-4-6): 0.15 to 80 MHz / 10V/m;
- Climate Test (IEC60068-21-14): -40°C +85°C / 72 hours;
- Vibration Resistance (IEC60255-21-1): 3-axis / 10 to 150 Hz / 2G / 160 min/axis;
- Vibration Response (IEC60255-21-1): 3-axis / 0.075mm-10 at 58 HZ / 1G from 58 to 150 Hz / 8 min / axis;

APPLICATION EXAMPLE

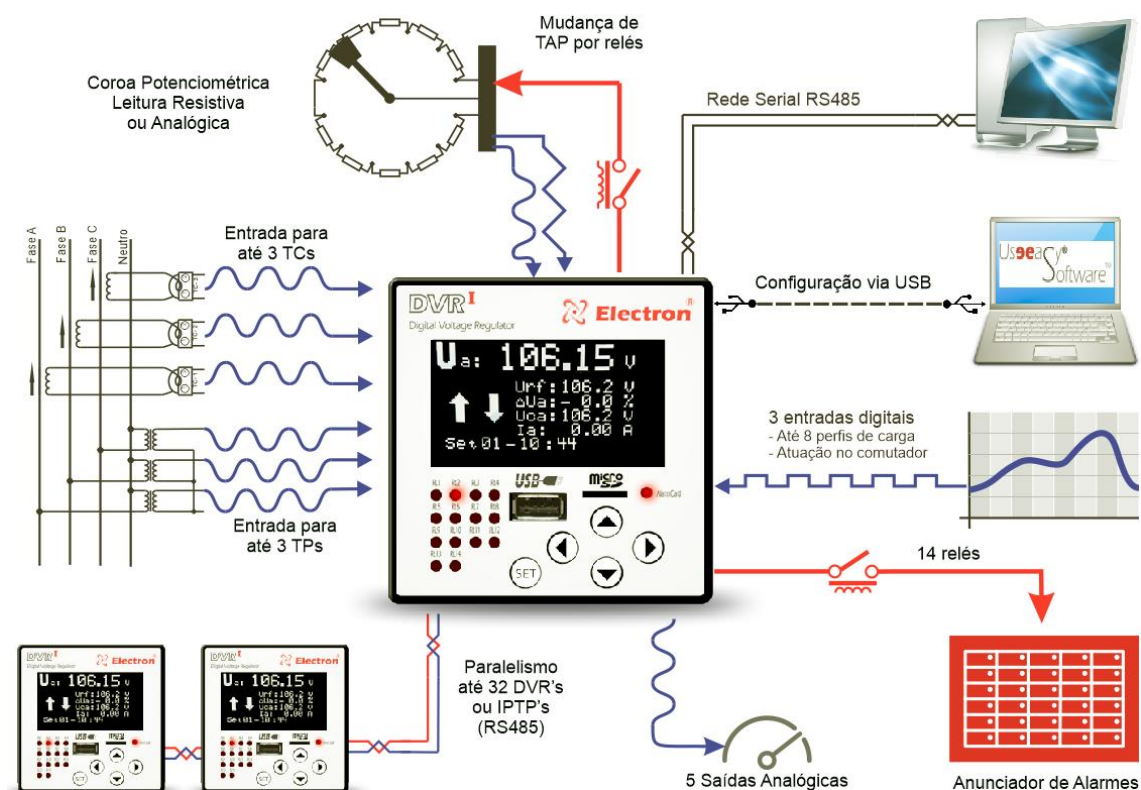
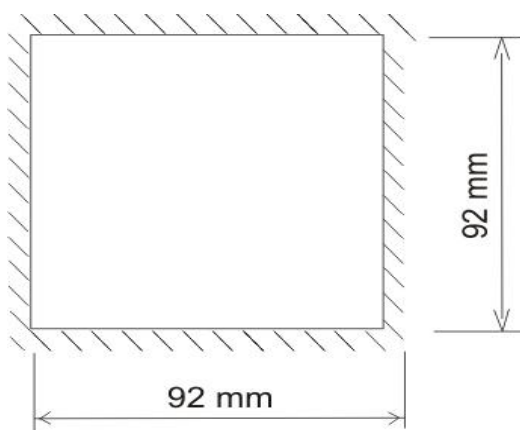
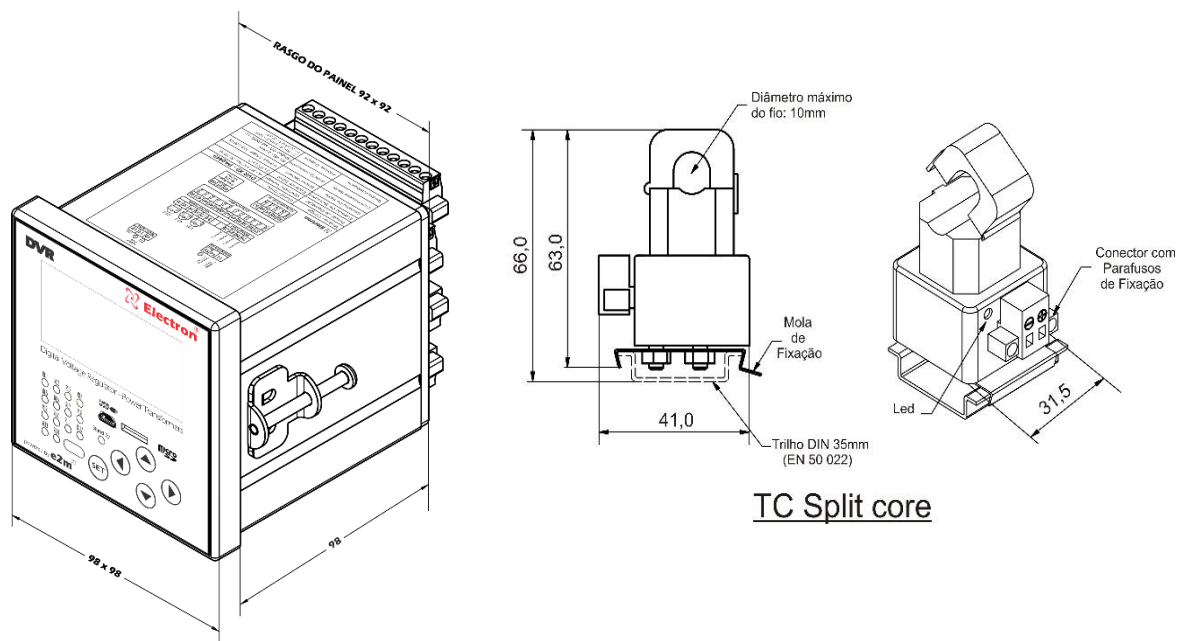


Figure 1- Application Example

DIMENSIONS



Rasgo do Painel

Figure 2 – Dimensions

CONNECTION DIAGRAM

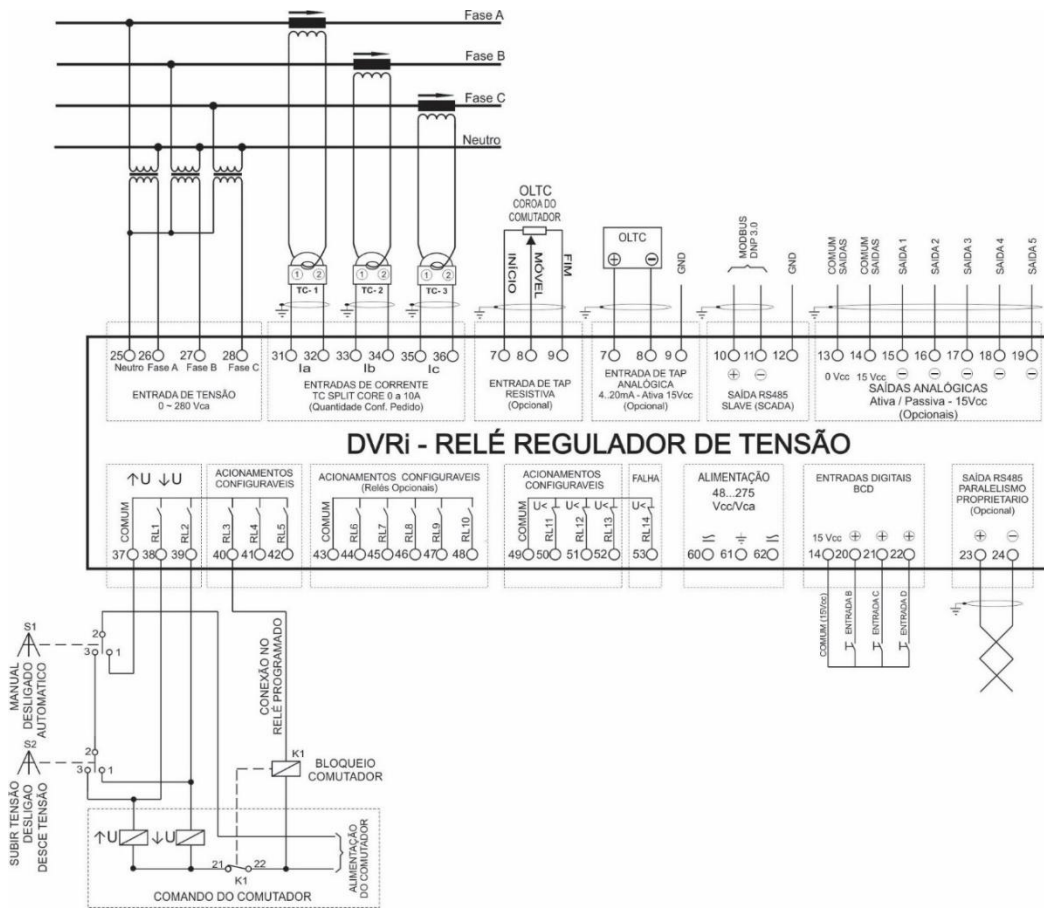


Figure 3 – Connection Diagram

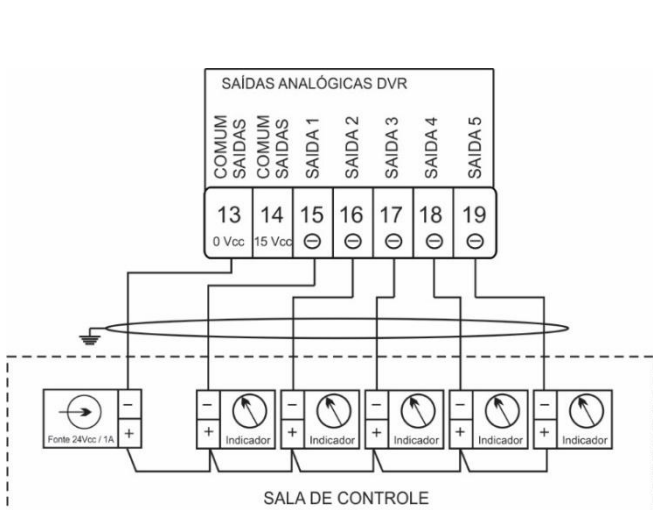


Diagrama para conexões de Indicadores Analógicos com fonte externa.

Figure 4 – Indicator connection diagram with external source

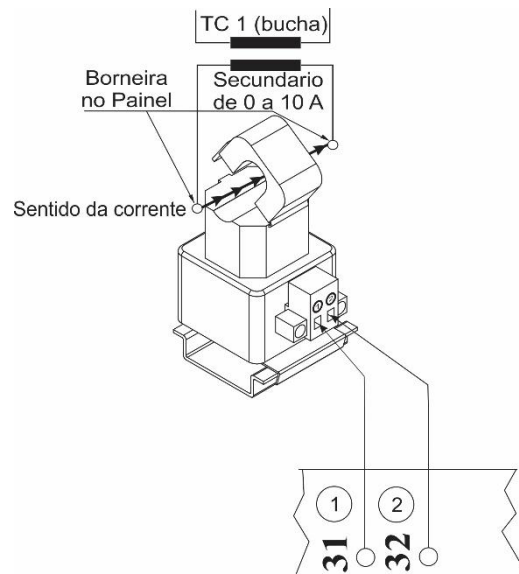


Diagrama de Ligação do TC 1

Figure 5 – TC connection diagram

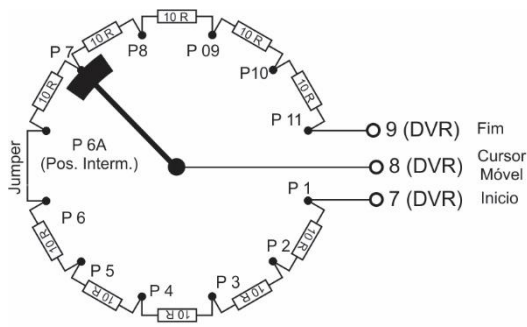


Diagrama de ligação OLTC coroa do comutador

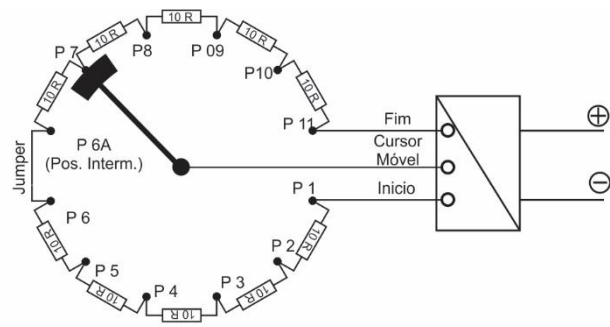


Diagrama de ligação OLTC coroa do comutador 4 a 20mA

Figure 6 – Crown Switch Connection Diagram Figure 7 – Crown Switch Connection Diagram 4*20mA

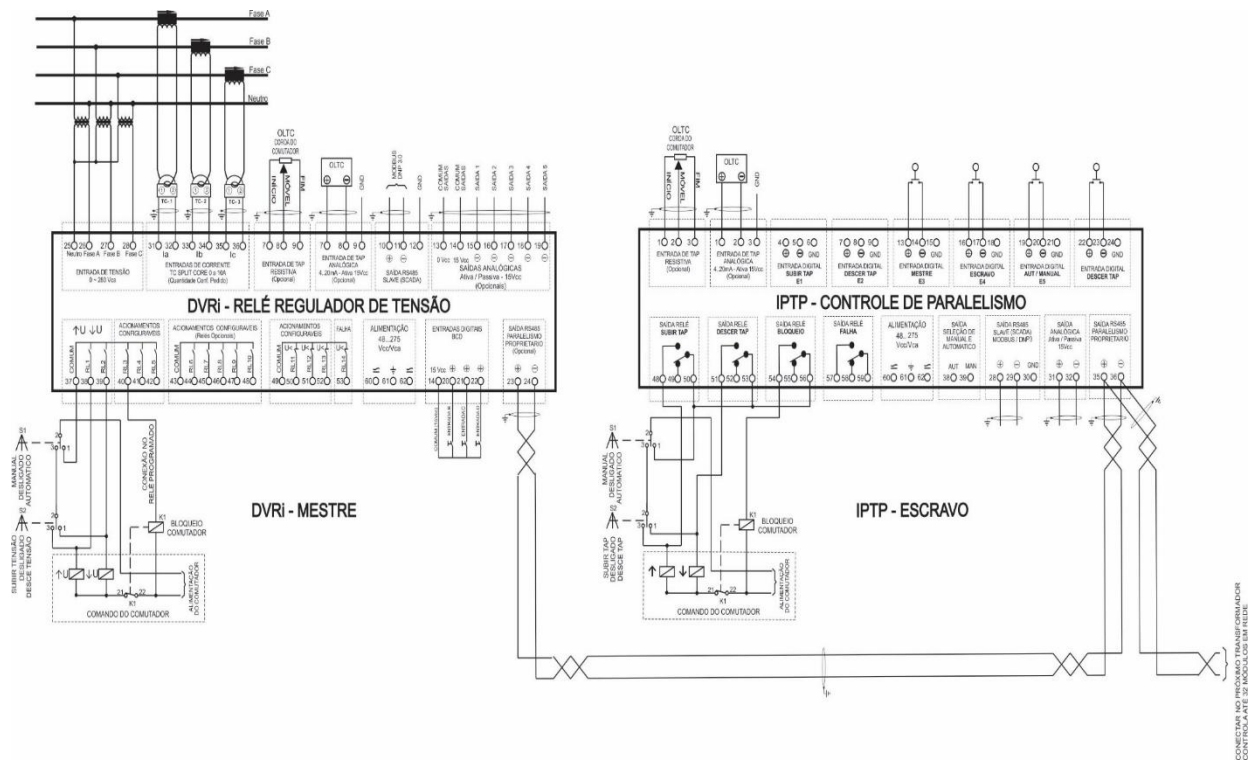
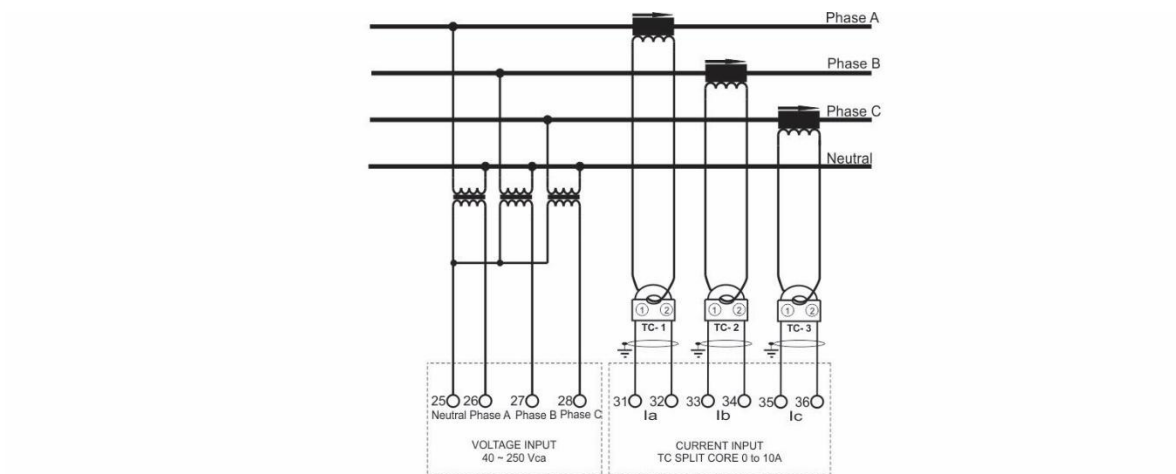
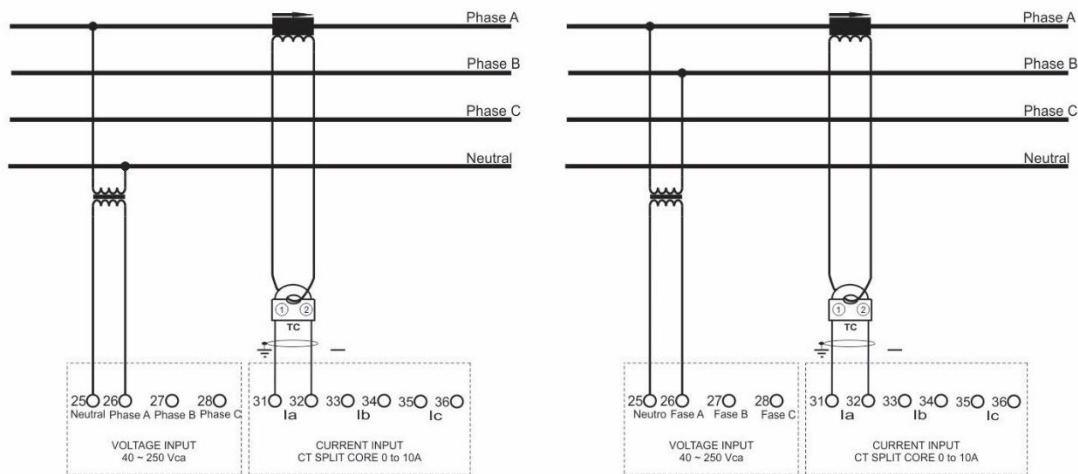


Figure 8 – DVR Master/IPTP Slave Link Diagram

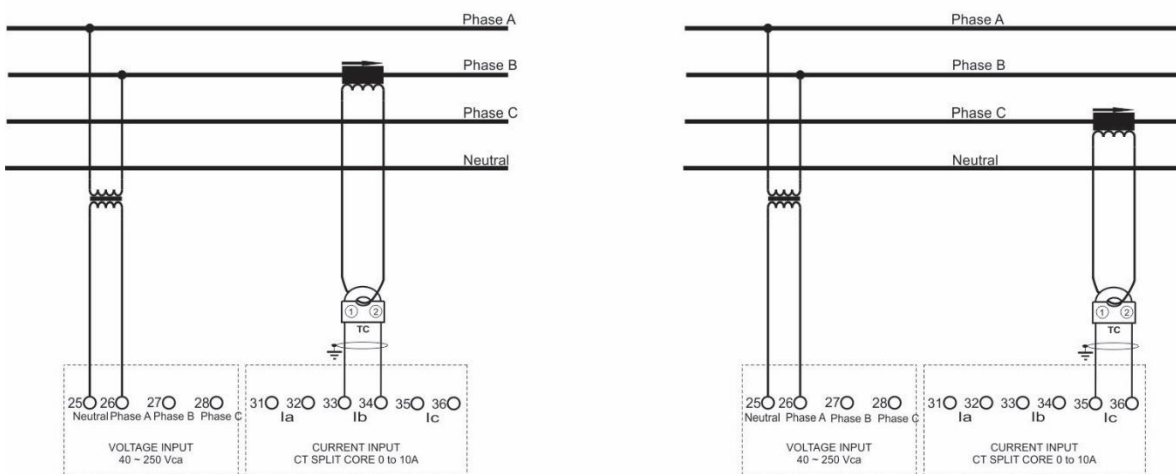


MEDIÇÃO DE 3 FASES



**MEDIÇÃO DE 1 FASE
DEFASAGEM DE 0°**

**MEDIÇÃO DE 1 FASE
DEFASAGEM DE 30°**



**MEDIÇÃO DE 1 FASE
DEFASAGEM DE 150°**

**MEDIÇÃO DE 1 FASE
DEFASAGEM DE 270°**

Figure 9 – 3-phase measurement diagram

RELÉ REGULADOR DE TENSÃO DIGITAL

DVR -

Medição de Corrente		Entrada de Medição de TAP	
1	1 TC Splitcore	0	Sem Entrada
2	2 TC's Splitcore	1	Entrada Resistiva
3	3 TC's Splitcore	2	Entrada Analógica

GETTING TO KNOW THE DVR

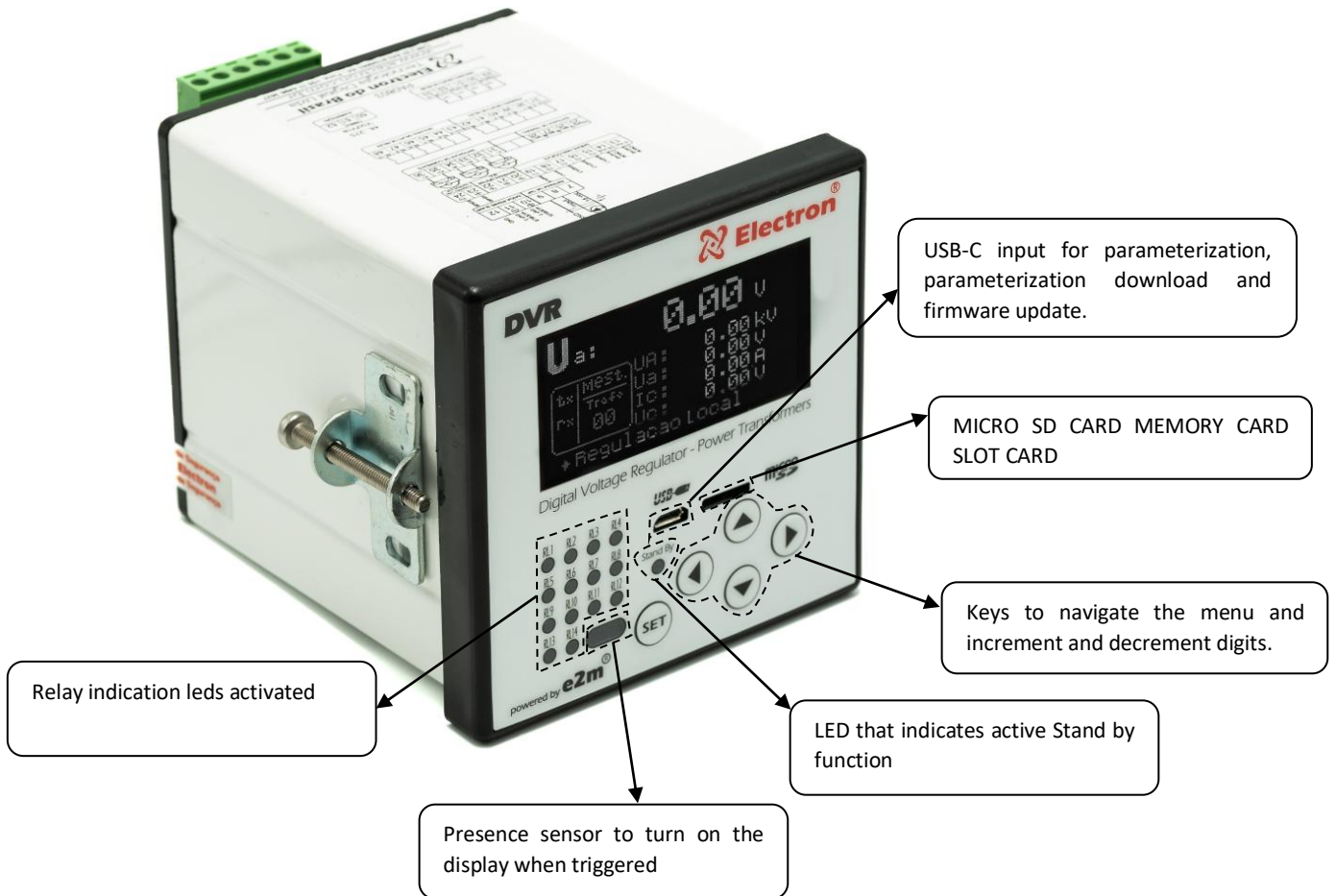


Figure 10 – Getting to know the DVR

DISPLAY CONFIGURATION

To access the display configuration, it is necessary to be in reading presentation mode. Press the arrow key to ▼ to select one of the five fields, with the ◀ or ▶ Select the desired variable that is displayed in the field and press the **SET**. To exit the display setup screen, navigate with the ▲ or ▼ to the 'back' option and press the key **SET**

The OLED display has 5 (five) fields for indicating quantities, which can be configured with the following options below:

NOTE: The variable is only available for display on the display if the DVR is configured to read the quantity:

Variables that can be indicated on the display	Form of Presentation	Unit
Current TAP position	$P_{TAP} : 0$	---
Voltage in TP secondary phase A	$U_a : 0.00$	V
Voltage at TP A primary	$U_A : 0.00$	kV
Voltage in TP secondary phase b	$U_b : 0.00$	V
Voltage at Primary in TP Phase A	$U_B : 0.00$	kV
Voltage in secondary TP phase C	$I_c : 0.00$	V
Voltage in primary TP phase C	$IC : 0.00$	kV
Current in secondary CT phase A	$I_a : 0.00$	A
Current in the primary of CT phase A	$I_A : 0.00$	kA
Current in the secondary of the CT phase b	$I_b : 0.00$	A
Current in the primary of the CT phase B	$I_B : 0.00$	kA
Current in the secondary of the CT phase c	$I_c : 0.00$	A
Current in the primary of CT phase C	$I_C : 0.00$	kA

Variables that can be indicated on the display	Form of Presentation	Unit
Apparent power in secondary phase a	$S_a : 0.00$	---
Apparent power in secondary phase A	$S_A : 0.00$	V
Apparent power in secondary phase b	$S_b : 0.00$	kV
Apparent power in primary phase B	$S_B : 0.00$	V
Apparent power in secondary phase c	$S_c : 0.00$	kV
Apparent power in primary phase C	$S_C : 0.00$	V
Active power in secondary phase A	$P_a : 0.00$	VA
Active power in primary phase A	$P_A : 0.00$	MVA
Active power in secondary phase b	$P_b : 0.00$	VA
Active power in primary phase B	$P_B : 0.00$	MVA
Active power in secondary phase C	$P_c : 0.00$	VA
Active power in primary phase C	$P_C : 0.00$	MVA
Reactive power in secondary phase A	$Q_a : 0.00$	W
Reactive power in primary phase A	$Q_A : 0.00$	MW
Reactive power in secondary phase b	$Q_b : 0.00$	W
Primary reactive power phase B	$Q_B : 0.00$	MW
Secondary reactive power phase c	$Q_c : 0.00$	W
Primary reactive power phase C	$Q_C : 0.00$	MW
Power factor phase A	$FP_a : 0.000$	---

Variables that can be indicated on the display	Form of Presentation	Unit
Power factor phase B	FP _b : 0.000	---
Power factor phase C	FP _c : 0.000	---
Voltage at Load Phase A Calculated	U _{C_A} : 0.00	kV
Percentage voltage variation in the secondary of the PT in phase a	ΔU _a : 0.00	%
Percentage Voltage Change in Load from Phase A Calculated	ΔU _{a_c} : 0.00	%
Voltage at Load Phase B Calculated	U _{C_B} : 0.00	kV
Percentage voltage variation in the secondary of the PT of phase b	ΔU _b : 0.00	%
Voltage at Load Phase C Calculated	U _{C_C} : 0.00	KV
Percentage voltage change in the secondary of the PT of phase c	ΔU _c : 0.00	%
Percentage Voltage Change in Load of Phase C Calculated	ΔU _{c_c} : 0.00	%
Reference voltage	U _{Ref} : 0.00	V
Frequency	F _{req} : 0.00	Hz
Percentage of Loading in Phase A Winding	%T _{C_A} : 0.00	%
Loading Percentage in Phase B Winding	%T _{C_B} : 0.00	%
Loading Percentage in Phase C Winding	%T _{C_C} : 0.00	%

SWITCH COMMAND MENU

The menu **Coman.** - Switch Command – contains the following options:

- Raise Voltage;
- Lower Voltage;

To access the command menu, a password is required. After pressing SET, a four-digit number will appear on the display, "Password reminder" at the top and "0000" in the center. Use the key to change the digit, to confirm the chosen number and move to the next digit press the button, to return to the previous digit press the button. Confirming the four digits press the **SET key**, if the password is correct, you will enter the configuration menu showing the configuration options. If the password is incorrect, an "Incorrect Password" message will appear at the bottom of the display and will display the digits **0000 again**.

The default manufacturing password of the DVR is 0000, in case of loss or forgetting of password contact Electron do Brasil informing the password reminder.

To navigate the setup menu using the ▲ ▼ keys. To enter the desired option, press the SET or ► key, to change the value of the variables use the ▲ ▼ keys and press the SET key to confirm the change, to cancel the operation press the ◀ key. Automatically the variable will return its previous value.

Menu	Variable	Description
Current Voltage		→ Menu to run the local command to raise voltage.
	DISP	Select the function on the Voltage Up display and press the SET key . When the operating mode is configured to accept local commands, the Voltage Up field will display DISP , indicating that the command is available.
	INDI.	When the command is unavailable, INDI will be shown. Note1: <i>The DVR only accepts local command when in the REGULA>>OP MODE MENU. is set to LOCAL or REMOTE/LOCAL.</i> Note2: <i>The DVR will not accept local command when in the REGULA>>OP MODE MENU. is set to AUTO or REMOTE, or the equipment is set to Parallelism network as Follower.</i>
Descend Voltage		→ Menu to run the local command to raise voltage.
	DISP	Select the function on the Lower Voltage display and press the SET key . When the operating mode is configured to accept local commands, the Lower Voltage field will display DISP , indicating that the command is available.
	INDI.	When the command is unavailable, INDI will be shown. NOTE1: <i>The DVR only accepts local command when in the REGULA>>OP MODE MENU. is set to LOCAL or REMOTE/LOCAL.</i> OBS2: <i>The DVR will not accept local command when in the REGULA>>OP MODE MENU. is set to AUTO or REMOTE, or the equipment is set to Parallelism network as Follower.</i>

MENU RESET

The **Reset** menu is a switch fault reset command menu and has the following function:

- RESET Fails;

To access the command menu, a password is required. After pressing SET, a four-digit number will appear, on the display, "Password reminder" at the top and "0000" in the center. Use the key to change the digit, to confirm the chosen number and move to the next digit press the button, to return to the previous digit press the button. Confirming the four digits press the **SET key**, if the password is correct, you will enter the configuration menu showing the configuration options. If the password is incorrect, an "Incorrect Password" message will appear at the bottom of the display and will display the digits 0000 again.

The default manufacturing password of the DVR is 0000, in case of loss or forgetting of password contact Electron do Brasil informing the password reminder.

To navigate the setup menu using the ▲▼ keys. To enter the desired option, press the SET or ► key, to change the value of the variables use the ▲▼ keys and press the SET key to confirm the change, to cancel the operation press the ◀ key. Automatically the variable will return its previous value.

Menu	Parameter	Variable	Description
Reset Failure			→ Menu to reset possible switching failures and fault in the parallelism network.
	---	---	Option to perform the reset of the switching fault and/or timing fault (if enabled). Select the Reset Switching Failure option and press the SET key.

CONSULTATION MENU

The Query menu **indicates**. It is to consult the following parameters:

- Switch Status;
- Voltage in the secondary;
- Voltage in the primary;
- Voltage on load;
- Color. In secondary;
- Color. In primary;
- apparent power;
- Active Power;
- Reactive Power;
- Power factor;
- Voltage deviation;
- TAP position;
- Switching Numbers;
- Load percentage;
- Date and time;
- TAP position;

To access the menu **indica.**, with the display in reading presentation mode. Press the **SET button** and the display will present a menu screen at the bottom, with the button navigate to the indicated menu., press the **SET key**.

Menu	Parameter	Variable	Description
	N.Op.last Maint.		Displays the number of operations performed by the switch since its last maintenance.
	N. Total Switching		Displays the total number of operations performed by the switch.
	Sum I ² Last Maint.		Sum of current switched by the changer squared since the last maintenance (KA).
	Total Sum I ²		Sum of current squared performed by the commutator in the period: Daily: Sum of current performed on the day; Weekly: Sum of current performed in the week; Monthly: Sum of operations performed during 1 (one) month. Quarterly: Sum of operations carried out during 3 (three) months; Semiannual: Sum of operations carried out during 6 (six) months; Annual: Sum of operations carried out during 1 (one) year;

Menu	Parameter	Variable	Description	
Switch Status	Quant. Of Switching		Number of Switches Performed by the Switch: Daily: Sum of operations performed during the day; Weekly: Sum of operations performed during the week Monthly: Sum of Current carried out during the Month; Quarterly: Sum of current performed during 3 (three) months; Semiannual Sum of current performed during 6 (six) months; Annual: Sum of current performed during 1 (one) year;	
	Hour Meter Switch		→ Submenu to check the amount of time the switch is running.	
		Partial Hour Meter	Period elapsed after maintenance (Time, Day and Year);	
		Total Hour Meter	Total elapsed period of the switch (Hour, Day, Year);	
	Next Maintenance			→ Estimates how long it takes to perform the next maintenance;
		By N. Commutations	Partial Hour Meter: Period elapsed after maintenance (Hour, day, year);	
		By Chain Sum	Total Hour Meter: Total time period of the switch (Hour, day, year);	

Menu	Parameter	Variable	Description
Switch Status	Maintenance History		→ This menu displays the last 5 maintenance performed on the switch (Date, Time, Number of switches and current sum);
	---	First maintenance Until Fifth Maintenance	Date: Days, Month and year of maintenance; Time: Maintenance Hours and Minutes; Switches: Number of operations, when maintenance was performed; Sum I²: Sum of current squared, when maintenance was performed;
Voltage in secondary	Phase A	0 to 280V	Displays the voltage value of the secondary of the phase a TP;
	Phase B	0 to 280V	Displays the voltage value of the secondary of the TP of phase b;
	Phase c	0 to 280V	Displays the voltage value of the secondary of the phase c TP;
Voltage at Primary	Phase A	0 to 999.99kV	Indicates the voltage value of the primary of the phase A TP;
	Phase B	0 to 999.99kV	Indicates the voltage value of the primary of the PT of phase B;
	Phase C	0 to 999.99kV	Indicates the voltage value of the primary of the PT of phase C;
Load Voltage	Phase A	0 to 999.99kV	Indicates the voltage value in the load of line A;
	Phase B	0 to 999.99kV	Indicates the voltage value in the load of line B;
	Phase C	0 to 999.99kV	Indicates the voltage value in the load of line C;
Cor. in Secondary	Phase A	0 to 9.999A	Displays the secondary current value of the CT of phase a;
	Phase B	0 to 9.999A	Displays the current value on the secondary of the CT of phase b;
	Phase c	0 to 9.999A	Displays the current value in the secondary of the CT of phase c;
Cor in primary	Phase A	0 to 999.9 KA	Indicates the primary current value of the Phase A TP;
	Phase B	0 to 999.9 KA	Indicates the primary current value of the Phase B TP;
	Phase C	0 to 999.9 KA	Indicates the primary current value of the PT of phase C;
Apparent Power in Secondary	Phase A	0 to 999.9 VA	Indicates the apparent power value of the phase a CT submit;
	Phase B	0 to 999.9 VA	Indicates the apparent power value of the secondary of the CT of phase b;
	Phase c	0 to 999.9 VA	Displays the apparent power value of the secondary CT of phase c;
Active Power in Secondary	Phase A	0 to 999.9 W	Displays the value of Active power in the secondary of the CT of phase a;
	Phase B	0 to 999.9 W	Displays the value of Active power in the secondary of the CT of phase b;
	Phase c	0 to 999.9 W	Displays the value of Active power in the secondary of the CT of phase c;
Reactive Power in secondary	Phase A	0 to 999.9 VAR	Indication of the reactive power value of the secondary of the CT of phase a;
	Phase B	0 to 999.9 Var	Indication of the reactive power value of the secondary CT of phase b;
	Phase c	0 to 999.9 VAR	Indication of the reactive power value of the secondary CT of phase c;
Power Factor	Phase A	-1 to 1	Indicates the value of the Power Factor of Phase A;
	Phase B	-1 to 1	Indicates the value of the Power Factor of Phase B;
	Phase C	-1 to 1	Indicates the value of the Power Factor of Phase C;
Voltage Deviation	Phase A	-100 to 100%	Displays the voltage deviation value of the secondary of the TP of phase a;
	Phase B	-100 to 100%	Displays the voltage deviation value of the secondary of the TP of phase b;
	Phase c	-100 to 100%	Displays the voltage deviation value of the secondary of the TP of phase c;

Menu	Parameter	Variable	Description
Load Percentage	Phase A	0 to 100%	Indicates the percentage of load in the winding of phase A;
	Phase B	0 to 100%	Indicates the percentage of load in the winding phase B;
	Phase C	0 to 100%	Indicates the percentage of load in the winding of phase C;
Date/Time	Date	-	Indicates the date the DVR is set to;
	Hour	-	Indicates what time the DVR is set to;
	Week	-	Indicates which day of the week the DVR is set to;
TAP Position	Pos. Minimum	-50 to 50	Minimum Position reached by the Switch;
	Pos. Maxim	-50 to 50	Maximum Position reached by the Switch;
	Pos. Current	-50 to 50	Current Switch Position;

SETUP MENU

The confi . You are set up the following parameters:

- OLED Display Setting;
- Output Conf. RS485;
- Current Output;
- Conf. Log. SDCard;
- Date/Time Conference;
- Digital Entry;
- Change of password;
- Relay – Actuation;
- Idioma / Language;
- Trigger Test;

To access the menu **Confi**. With the display in reading display mode. Press the **SET** The display will present at the bottom a menu screen, with the Navigate to Menu key **confi**, press the **SET**.

The menu **confi** It has a password for navigation, right after pressing the key **SET** a four-digit number will appear on the display, "Password reminder" at the top and "0000" in the center. Use the key to change the digit, to confirm the chosen number and move to the next digit press the key, to return to the previous digit press the key **ESC**. Confirming the four digits press the **SET**, if the password is correct, enter the configuration menu showing the configuration options. If the password is incorrect, an "Incorrect Password" message will appear at the bottom of the display and will display the digits again **000**.

After entering the password, the DVR will only ask for the password again when it returns to its measurement indication screen, if you continue to make configuration in other menus that have a password, the DVR will not ask for the password again.

The default manufacturing password of the DVR is 0000, in case of loss or forgetting of password contact Electron do Brasil informing the password reminder.

To navigate the setup menu using the keys. To enter the option, press the key **SET** Or, to change the value of the variables, use the keys and press the **SET** to confirm the change. To cancel the operation, press the keys. Automatically the variable will return its previous value.

Menu	Parameter	Variable	Description
OLED Display Setting	→ Menu to perform the setting in the display presentation mode and perform.		
	Contrast	→ Submenu to configure the display contrast;	
		0 to 255	Display contrast setting value;
	Display Mode	→ Submenu to configure the OLED Display screen viewing mode	
		Black	Black screen written in white;
		White	White screen written in black;
	→ Submenu to configure the display mode of the quantities in the first one.		
	Presentation	Fixed	It will present only one quantity in the first line, according to the choice that the user configures;
		Scan	The quantities configured by the user will be displayed sequentially (To perform the set of these quantities use the Useeasy software);
	LED Test & Display	→ Submenu to test the activation of the LED's and OLED Display Screen.	
---		Press and hold the SET key and check if all the LEDs on the front of the DVR should be lit (During this test the Display will alternate the display color, that is, if it is Black it will display White and if it is White it will display Black);	
CheckoutRS485	→ Menu to perform the configuration of serial communication network parameters (Supervisory / SCADA).		
	→ Submenu to select the Serial Communication Protocol;		
	Protocol	MBUS	Defines the MODBUS RTU as a Communication Protocol;
		DNP	Defines DNP3 Level 2 as Communication Protocol;
	Address	→ Submenu to configure serial network address.	
		1 to 254	Each equipment connected to the RS485 network (terminal 10, 11 and 12) must have a single address, different from the others, so that the supervisor (SCADA) can identify the DVR;
	Baudratekbps	→ Submenu to select serial network communication speed	
		AUTO	Automatically detects the communication speed;
		2.4	Sets the serial communication speed at 2.4000 b/s;
		4.8	Sets the serial communication speed at 4,800 b/s;
		9.6	Sets the serial communication speed at 9,600 b/s;
		19.2	Sets the serial communication speed at 19,200 b/s;
		38.4	Sets the serial communication speed at 38,400 b/s;
	Parity	→ Submenu for communication parity setting, i.e. set the last bit to be transmitted in the message for data integrity check.	
		NONE	No Parity;
ODD		Last bit of the message will be 1;	
PAIR		Last bit of the message will be 0;	

Menu	Parameter	Variable	Description	
CheckoutRS485	Network Protection		→ Submenu for configuring serial network parameter protection	
		Off	Disables the protection system against parameter changes, allowing the change of parameters in the serial network;	
		On	Enables the protection system against parameter changes, not allowing the change of parameters in the serial network;	
			→ Menu to configure the type and range of the current outputs.	
	SCALE		→ Submenu for choosing and setting the current output range	
		0-1 mA	Configures the current output range at 0 to 1 mA;	
		0-5 mA	Configures the current output range at 0 to 5 mA;	
		0-10 mA	Configures the current output range from 0 to 10 mA;	
		0-20 mA	Configures the current output range from 0 to 20 mA;	
		4-20 mA	Configures the current output range at 4 to 20mA;	
	Output 1 Output 2 Output 3 Output 4 Output 5			→ Submenu to configure the quantity to be mirrored by each of the 5 analog outputs
		OFF	Analog output disabled;	
		COR A	Mirrors the secondary current of phase A CT;	
		COR B	Mirrors the secondary current of the phase B TC;	
		COR C	Mirrors the secondary current of the CT of phase C;	
		FASE A	Mirrors the secondary voltage of phase A TP;	
		FASE B	It mirrors the secondary voltage of the TP of phase B;	
		FASE C	Mirrors the secondary voltage of the phase C TP;	
		FPot A	Mirrors the power factor of phase A;	
		FPot B	Mirrors the power factor of phase B;	
		FPot C	Mirrors the power factor of phase C;	
		Ativ A	Mirrors the active power of the secondary of the Phase A TP;	
		Ativ B	Mirrors the active power of the secondary of the Phase B TP;	
		Ativ C	Mirrors the active power of the Phase C TP sub	
		Reat A	Mirrors the reactive power of the secondary of the Phase A PT;	
		Reat B	Mirrors the reactive power of the secondary of the phase B TP;	
		Reat C	Mirrors the reactive power of the secondary of the C phase PT;	
		Apar A	Mirrors the apparent secondary power of the Phase A TP;	
		Apar B	Mirrors the apparent secondary power of the PT of phase B;	
		Apar C	Mirrors the apparent secondary power of the Phase C TP;	
		△Ref A	Mirrors the voltage variation of the secondary of the TP of phase A;	
		△Ref B	Mirrors the voltage variation of the secondary of the TP of phase B;	
		△Ref C	Mirrors the voltage variation of the secondary of the C phase TP;	


Menu	Parameter	Variable	Description
Current output	Range Output Color;		→ Submenu to configure the minimum and maximum range of the analog output.
		Min Out Max Out	Before determining the range, you need to check the analog output range and analog output variable previously selected in the SCALE and Output submenus . Example: Range = 4 to 20 mA, Output 1 = Phase A (Which has a range of 0 to 150 V). So Min Out = 0 V Max Out = 150 V Thus, Min Out (0 V) the signal will be 4 mA and when we get Min Max (150 V), the signal will be 20 mA.
Conf. Log. SD Card	Aquisi time.		→ Menu to set parameters for recording on the Micro SD Card.
		Off	→ Submenu for setting Equipment Health Log time on Micro SD Card memory card OFF: Log by off time;
		5 to 180	Writes the Log to the value in minutes determined in this menu. For instance. If the selected value is 5, then every 5-minute interval the recording will occur
Conf. Date/Time			→ Menu to set date and time on the DVR's internal clock.
	Date	Day/Month/Year	→ Submenu for setting Clock Date;
	Hour	Hours:Minutes	→ Submenu for setting clock hours;
	Week	---	→ Submenu for setting the day of the week of the clock. NOTE: The day of the week will be displayed according to the parameters entered in the Date submenu (Day/Month/Year);

Menu	Parameter	Variable	Description																																			
	→Menu to configure the digital input function.																																					
	Commands	OFF	Disables the Commands parameter;																																			
		ON	Configures the digital input commands for instructions to raise the voltage. Input B, pin 20 = Raise Voltage; Input C, pin 21 = Lower voltage;																																			
	Cj. Regulation	OFF	Disables the CJ Regulation Parameter;																																			
		ON	<p>Configures the digital input to select the Throttle Set. That is, the DVR will only select the enabled parameters. 0 – Open Selector Switch; 1 – Closed selector switch;</p> <table border="1"> <thead> <tr> <th>B</th> <th>C</th> <th>D</th> <th>BCD Inputs</th> </tr> </thead> <tbody> <tr> <td>0</td> <td>0</td> <td>0</td> <td>Select the setting set 1.</td> </tr> <tr> <td>0</td> <td>0</td> <td>1</td> <td>Select the setting set 2.</td> </tr> <tr> <td>0</td> <td>1</td> <td>0</td> <td>Select the setting set 3.</td> </tr> <tr> <td>0</td> <td>1</td> <td>1</td> <td>Select the setting set 4.</td> </tr> <tr> <td>1</td> <td>0</td> <td>0</td> <td>Select the setting set 5.</td> </tr> <tr> <td>1</td> <td>0</td> <td>1</td> <td>Select the setting set 6.</td> </tr> <tr> <td>1</td> <td>1</td> <td>0</td> <td>Select the setting set 7.</td> </tr> <tr> <td>1</td> <td>1</td> <td>1</td> <td>Select the setting set 8.</td> </tr> </tbody> </table> <p>NOTE: The digital input can only adopt one of the four enabled parameters. Among them, Commands, Cj. Regulation, Regulation Mode or Parallelism. Only one parameter will be enabled;</p>	B	C	D	BCD Inputs	0	0	0	Select the setting set 1.	0	0	1	Select the setting set 2.	0	1	0	Select the setting set 3.	0	1	1	Select the setting set 4.	1	0	0	Select the setting set 5.	1	0	1	Select the setting set 6.	1	1	0	Select the setting set 7.	1	1	1
B	C	D	BCD Inputs																																			
0	0	0	Select the setting set 1.																																			
0	0	1	Select the setting set 2.																																			
0	1	0	Select the setting set 3.																																			
0	1	1	Select the setting set 4.																																			
1	0	0	Select the setting set 5.																																			
1	0	1	Select the setting set 6.																																			
1	1	0	Select the setting set 7.																																			
1	1	1	Select the setting set 8.																																			

Menu	Parameter	Variable	Description																										
	Setting Mode	OFF	Disables the Adjustment Mode parameter;																										
		ON	<p>Configures the Digital Input to select the operating mode for Regulation;</p> <table border="1"> <thead> <tr> <th>B</th> <th>C</th> <th>D</th> <th>BCD Inputs</th> </tr> </thead> <tbody> <tr> <td>0</td> <td>0</td> <td>0</td> <td>Obeys the parameter configured in the Adjustment Menu;</td> </tr> <tr> <td>0</td> <td>0</td> <td>1</td> <td>Digital input enabled as Automatic Regulation;</td> </tr> <tr> <td>0</td> <td>1</td> <td>0</td> <td>Digital input enabled as Local Operation;</td> </tr> <tr> <td>1</td> <td>0</td> <td>0</td> <td>Digital input enabled as Remote Operation;</td> </tr> <tr> <td>1</td> <td>1</td> <td>0</td> <td>Digital input enabled as Local and Remote Operation;</td> </tr> <tr> <td>1</td> <td>1</td> <td>1</td> <td>Digital input enabled as Switch Lock;</td> </tr> </tbody> </table> <p>NOTE: The digital input can only adopt one of the four enabled parameters. Among them, Commands, Cj. Regulation, Regulation Mode or Parallelism. Only parameter one will be enabled;</p>	B	C	D	BCD Inputs	0	0	0	Obeys the parameter configured in the Adjustment Menu;	0	0	1	Digital input enabled as Automatic Regulation;	0	1	0	Digital input enabled as Local Operation;	1	0	0	Digital input enabled as Remote Operation;	1	1	0	Digital input enabled as Local and Remote Operation;	1	1
B	C	D	BCD Inputs																										
0	0	0	Obeys the parameter configured in the Adjustment Menu;																										
0	0	1	Digital input enabled as Automatic Regulation;																										
0	1	0	Digital input enabled as Local Operation;																										
1	0	0	Digital input enabled as Remote Operation;																										
1	1	0	Digital input enabled as Local and Remote Operation;																										
1	1	1	Digital input enabled as Switch Lock;																										
	Parallelism	OFF	Disables the Parallelism parameter;																										
		ON	<p>Configures the Digital Input to select the equipment operating mode as Parallelism;</p> <table border="1"> <thead> <tr> <th>B</th> <th>C</th> <th>D</th> <th>BCD Input</th> </tr> </thead> <tbody> <tr> <td>0</td> <td>0</td> <td>0</td> <td>No function, responds to the parameter configured in Parallelism;</td> </tr> <tr> <td>0</td> <td>0</td> <td>1</td> <td>Master Parallelism Option;</td> </tr> <tr> <td>0</td> <td>1</td> <td>0</td> <td>Follower Parallelism option;</td> </tr> <tr> <td>1</td> <td>0</td> <td>0</td> <td>Option Individual Parallelism Phase;</td> </tr> <tr> <td>1</td> <td>1</td> <td>0</td> <td>Individual Parallelism Option Bank (Only in the Bank Topology);</td> </tr> <tr> <td>1</td> <td>1</td> <td>1</td> <td>Parallelism option off;</td> </tr> </tbody> </table> <p>NOTE: The digital input can only adopt one of the four enabled parameters. Among them, Commands, Cj. Regulation, Regulation Mode or Parallelism. Only one parameter will be enabled;</p>	B	C	D	BCD Input	0	0	0	No function, responds to the parameter configured in Parallelism;	0	0	1	Master Parallelism Option;	0	1	0	Follower Parallelism option;	1	0	0	Option Individual Parallelism Phase;	1	1	0	Individual Parallelism Option Bank (Only in the Bank Topology);	1	1
B	C	D	BCD Input																										
0	0	0	No function, responds to the parameter configured in Parallelism;																										
0	0	1	Master Parallelism Option;																										
0	1	0	Follower Parallelism option;																										
1	0	0	Option Individual Parallelism Phase;																										
1	1	0	Individual Parallelism Option Bank (Only in the Bank Topology);																										
1	1	1	Parallelism option off;																										
Password change	→ Menu for setting a password to access the DVR configuration menus.																												
	----	0000 to 9999	The manufacturing password of the DVR is 0000 . In case of loss or forgetfulness of password, contact Electron do Brasil and inform the password reminder.																										

Menu	Parameter	Variable	Description
Drive relays Relay 1 Relay 2	→ This menu is to configure the activation of relays 1 and 2 that are responsible for the command of Voltage up and down.		
	Logic	→ Submenu to configure the Relay activation logic.	
		Normal	Initial Condition of Relay Off;
	Kind	Reverse	Initial condition of the Activated Relay;
		→ Submenu to configure the type of Relay trigger.	
	Time	Constant	Relay will trigger and continue to trigger during the switching time;
		Wrist	Relay will trigger and continue to trigger for the period configured in the Time parameter .
Time	→ Submenu to configure the Relay Pulse Time.		
	500 to 5000 mS (millisecond)	This function is available only when the Drive Type is set to Pulse . When this parameter is enabled, the Relay will remain triggered for as long as it is parameterized by the user.	
Drive relays Relay 3 Relay 4 Relay 5 Relay 6 Relay 7 Relay 8 Relay 9 Relay 10 Relay 11 Relay 12 Relay 13	→ Menu to configure the activation of Relays 3 to 13.		
	Function	→ Submenu to configure which function the relay will perform;	
		No Function	Relay without any function;
		Command	Enables the Relay Command function;
		Alarm	Enables the Alarm function for the Relay;
	Logic	Fault	Enable the Failure function;
		→ Submenu to configure the type of Relay trigger.	
		Normal	Initial Condition of Relay Off;
	Kind	Reverse	Initial condition of the Activated Relay;
		→ Submenu to configure the type of Relay trigger. NOTE: When set to constant the relay pulse time will be OFF;	
		Constant	Relay will trigger and continue to trigger during the switching time;
	Time	Wrist	Relay will trigger and continue to trigger during the period configured in the Time parameter;
		→ Submenu to configure the Relay Pulse Time.	
Time	500 to 5000 mS (millisecond)	This function is available only when the Drive Type is set to Pulse . When this parameter is enabled, the Relay will remain triggered for as long as it is parameterized by the user.	

Menu	Parameter	Variable	Description
Drive Relays Relays 3 to 13	Relay Triggering	→ Submenu to configure the activation of the Command Relay. Only one command can be enabled. NOTE: When configured with the command function, the TYPE and TIME parameters are now the same as those configured in relay 1 (up voltage) and relay 2 (down voltage);	
		Lower Voltage	OFF Disables command to Lower Voltage; ON Enable command to Lower Voltage;
		→ Submenu to configure the activation of the Command Relay. Only one command can be enabled. NOTE: When configured with the command function, the TYPE and TIME parameters are now the same as those configured in relay 1 (up voltage) and relay 2 (down voltage);	
		Rising Voltage	OFF Disables the command to Raise Voltage; ON Enable command to Raise Voltage;
		→ Relay Configuration with the Surge Alarm function;	
		Undervoltage	OFF Disables Undervoltage Alarm; ON Enables Undervoltage Alarm;
		→ Relay Configuration with Over Current Alarm function;	
		Upon Cor.	OFF Disables Overcurrent Relay Alarm; ON Enables Over Current Relay Alarm;
		→ Relay Configuration with Compensation Limit Alarm function;	
		Limit. Compen	OFF Disables Compensation Limit Relay Alarm; ON Enables Limit Relay Alarm Compensation;
		→ Alarm Relay Configuration with Over Current Alarm function;	
		Cor. Reverse	OFF Disables Reverse Current Alarm; ON Enables Reverse Current Alarm;
		→ Alarm Relay Configuration with Maintenance and Switching function;	
		Maint. Switching.	OFF Disables Switch Maintenance Alarm; ON Enables Switch Maintenance Alarm;
		→ Configuration of the types of fault that the Relay can act when using the Fault function;	
		Limit. Compen	OFF Disables Compensation Threshold Failure; ON Enables Compensation Limit Failure;
		Color. Reverse	OFF Disables reverse current; ON Enables reverse current;

Menu	Parameter	Variable	Description
Drive Relays Relays 3 to 13	Relay Triggering	Maint.	OFF
		Switching.	ON
		→ Submenu to configure the Relay activation logic	
Relay drive Relay 14	Logic	Normal	Initial condition of the Relay Off;
		Reverse	Initial condition of relay Triggered;
Idioma / Language	→ Menu to select the language displayed on the DVR display;		
	---	Portuguese	Presentation language defined in Portuguese;
		English	Presentation language set in English;
Drive Test	→ Menu to test the Relay activations in order to check the installation;		
	---	Relay Drive 1 to Relay Drive 14	Attention when using this menu, it activates the relay outputs so that the operator can make sure they work, but if the DVR is in operation and the relays are connected to give commands and in the protection of the system, the relay will be activated.  Select the Relay and press the SET key to perform the drive.

MENU PROTECTION

The PROTECTION Menu: Configuration menu for the switch's protections and has the following submenus:

- Undervoltage;
- Overvoltage;
- Overcurrent;
- Reverse Current;
- Failure of Regulation;
- Switching Failure;
- Maximum and Minimum TAP

To access the **prote** menu with the display in reading presentation mode. Press the **SET** key the display will present a menu screen at the bottom, with the **▶** key navigate to the **protection** menu, press the **SET** key.

The **prote** menu has a password for your navigation, soon after pressing the SET key, a four-digit number will appear on the display, "password reminder" at the top and in the center **0000**. Use the **▲** or **▼** key to change the digits, to confirm the chosen number and move to the next number press the **▶** key, to return to the previous number press the **◀** key. Confirming the four digits press the SET key, if the password is correct, you will enter the configuration menu showing the configuration options. If the password is incorrect, an "incorrect password" message will appear at the bottom of the display and will show **0000** again.

After entering the password, the DVR will only ask for the password again when it returns to its measurement indication screen, if you continue to make configuration in other menus that have a password, the DVR will not ask for the password again.

From the factory the DVR password is 0000. In case of loss or forgetfulness of the password, please contact Electron do Brasil informing the password reminder.

To navigate the setup menu using the **▲▼** keys. To enter the desired option, press the SET or **▶** key, to change the value of the variables use the **▲▼** keys and press the SET key to confirm the change, to cancel the operation press the **◀** key. Automatically the variable will return its previous value.

Menu	Parameter	Variable	Description
	→ Menu to configure Undervoltage protection:		
	Blockade	→ Submenu to enable or disable Undervoltage locking.	
		OFF	Enables switch lockout due to undervoltage;
		ON	Disables Switch Lock due to Undervoltage;

Menu	Parameter	Variable	Description
Undercurrent	→ Percentage of deviation in the secondary of the PT for the undervoltage drive;		
	Blockade	OFF	Disables switch locking;
		ON	Enables switch locking;
	→ Delay time for blocking actuation after undervoltage detection;		
	Detour	Percentage of Deviation by undervoltage blockage;	
		10 to 99%	Percentage of deviation for undervoltage blocking;
	Retardation	→ Delay time for blocking actuation after undervoltage detection;	
		0 to 1200 sec	Time in seconds for blocking action;
	Hysteresis	→ Return hysteresis of undervoltage blocking;	
		0 to 25%	Value in seconds for blocking actuation;
Relay-drive	→ Choice of Relay for undervoltage drive:		
	---	This is a shortcut to setting up the relays from the setup menu on page 17. Relays 3 to 13 can be configured for alarm function and undervoltage activation. In this case, all relays selected to act by Undervoltage will be subject to the parameters configured for this protection.	
About Current	→ Menu to enable or disable Reverse Current locking;		
	Reverse Current	OFF	Enables reverse current switch lockout;
		ON	Disables reverse current switch lockout;
	→ Menu to enable or disable the lock due to regulation failure;		
	Adjustment Failure	OFF	Disables switch lock for switching failure;
		ON	Enables switch locking for Switching Failure;
	→ Menu to enable or disable switching failure lock		
	Switching Failure	OFF	Disables switch lock for switching failure;
ON		Enables switch locking for Switching Failure.	
→ Menu to enable or disable Maximum or Minimum TAP locking:			
Maximum and Minimum TAP	OFF	Disables the switch lock by maximum or minimum TAP;	
	ON	Enables the locking of the switch by maximum or minimum TAP;	

MENU ADJUSTMENT

The Regula menu. is a menu for configuring the parameters for the calculations of voltage regulation and the regulation sets and has the following submenus:

- Op Mode;
- C. Regulation 4;
- Reg. Phase;
- C. Regulation 4;
- C. Regulation 1;
- C. Regulation 5;
- C. Regulation 2;
- C. Regulation 6;
- C. Regulation 3;
- C. Regulation 7;
- C. Regulation 8;

To access the menu **regulates.** with the display in reading mode. Press the **SET button** and the display will present a menu screen at the bottom, with the ► button navigate to the adjust menu., press the **SET key**.

The menu **regulates.** has a password for your browsing, soon after pressing the SET key, a four-digit number will appear on the display, "password reminder" at the top and in the center **0000**. Use the ▲ or ▼ key to change the digits, to confirm the chosen number and move to the next number press the ► key, to return to the previous number press the ◀ key. Confirming the four digits press the SET key, if the password is correct, you will enter the configuration menu showing the configuration options. If the password is incorrect, an "incorrect password" message will appear at the bottom of the display and will show **0000 again**.

After entering the password, the DVR will only ask for the password again when it returns to its measurement indication screen, if you continue to make configuration in other menus that have a password, the DVR will not ask for the password again.

*From the factory the DVR password is **0000**. In case of loss or forgetfulness of the password, please contact Electron do Brasil informing the password reminder.*

To navigate the setup menu using the ▲ ▼ keys. To enter the desired option, press the SET or ► key, to change the value of the variables use the ▲ ▼ keys and press the SET key to confirm the change, to cancel the operation press the ◀ key. Automatically the variable will return its previous value.

Menu	Parameter	Variable	Description
OP MODE.	→ Menu to configure the dimmer mode;		
	Your location	Automatic	The DVR will execute the commands automatically, based on the settings values;
		Local	Enables the user to execute commands through the DVR display;
		Remote/Local	The DVR will be able to receive commands to raise and lower voltage remotely;
	Blockade	The DVR will block the execution of voltage up and down commands;	
Stand Alone	→ Menu to enable and/or disable the Stand-Alone operating mode		
	---	Yes	Enables the option with Stand Alone, that is, if communication with the remote is lost, the regulator's operating mode;
		No	Disables the Stand-Alone option; NOTE: Menu available only if the regulator operating mode is set to Remote ;
Reg. Phase	---	PHASE A A	Sets the TP measurement between phase A and neutral as a reference for the regulation calculations. Note: Automatically the current reading of phase A is enabled and allows the configuration for voltage and current readings of the other phases in the Trafo menu.
		PHASE B B	Sets the TP measurement between phase B and neutral as a reference for the regulation calculations. Note: Phase B current reading is automatically enabled and allows configuration for voltage and current readings from other phases in the Trafo menu.
		PHASE C C	Sets the TP measurement between phase C and neutral as a reference for the regulation calculations. Note: Automatically the current reading of phase C is enabled and allows the configuration for voltage and current readings of the other phases in the Trafo menu.

Menu	Parameter	Variable	Description
Reg. Phase	---	ABA PHASE	Sets the TP measurement between the AB phases as a reference for the regulation calculations and the current measurement of phase A. Note: automatically the readings of the other phases for voltage and current are disabled.
		ABB PHASE	Sets the PT measurement between AB phases as a reference for the regulation calculations and the B-phase current measurement. Note: automatically the readings of the other phases for voltage and current are disabled.
		ABC PHASE	Sets the TP measurement between the AB phases as a reference for the regulation calculations and the C phase current measurement. Note: automatically the readings of the other phases for voltage and current are disabled.
Set No. 1 to 8	→ Menu to configure the parameters of the adjustment sets. Configuration of Set 1 only is required. The other sets, if not used, leave the setting in OFF.		
	---	ON	Enables the configuration set;
	---	OFF	Disables the configuration set;
	→ Submenu to configure the reference voltage for regulation;		
	Voltage	40 Vac to 280 Vac	Desired load voltage with reference to the secondary voltage of the TP. TP ratio = $13,800\text{ V} / 115\text{ V} = 120\text{ V}$ Desired voltage at load = 13,200 V Nominal voltage = $13,200\text{ V} / 120\text{ V} = 110\text{ V}$
	→ Submenu to configure the timing type for the switch command.		
	C. Operation	Linear	The time to command the switch is the same as that set in the parameters T. up and T. down.
Reverse		The time to control the switch is inversely proportional to the voltage deviation from the rated voltage. The greater the deviation, the faster the DVR will send the command to the switch. Command Time = T rise (configured deviation / measured deviation); Command Time = T Descend (Configured Deviation / Measured Deviation);	
Step		It has 3 configurable deviation levels, each with its voltage up and down time setting;	
Compensation Conf.	→ Menu to configure the line offset/offset type.		
	LDC Type	→ Menu to configure the line drop compensation type	
		None	Disregards the Resistive (R), Reactive (x) and Fall (Z) drop configurations;
		RX	It is typically used when the voltage drop in the line is most significant. It is necessary to configure two-line parameters when the RX option ;
Z	It is normally used when the voltage drop in the line is relatively small. You must configure the Z drop parameter .		

Menu	Parameter	Variable	Description
Compensation Conf.	Fall R		→ Menu to configure the resistive voltage drop component in the line in Volts;
		- 25V to 25V	Option used when RX compensation mode is selected Rated current of TC 5 A. • Fall R = 5 * R * (TC Ratio / TP Ratio). Where: <i>R is the reactance of the transformer line to the load ohms Ω</i> ;
	Drop X		→ Menu to configure the resistive voltage drop component in the line in Volts;
		- 25V to 25V	Option used when RX compensation mode is selected Rated current of TC 5 A. • Drop X = 5 * X * (TC Ratio / TP Ratio). Where: <i>X is the reactance of the transformer line to the load ohms Ω</i>
	Comp. Z		→ Menu to configure the voltage drop on the line in percentage.
		0 to 15 %	Option used when the Z compensation mode is selected. Value of the percentage of voltage drop in the line. Adjusted the rated current of the DVR (5A). Comp. Z = 100. <u>Voltage in Trafo - Voltage in Load. 5.TC interface</u> Voltage in Traffic Load Current
Comp. MAX		→ Menu to configure the maximum allowable compensation for regulation;	
	10 to 25%	Value in percentage of the voltage to avoid high output voltage in the transformer causing a high current in the load; NOTE: <u>The percentage of deviation is from the secondary of the PT</u>	
Detour		→ Menu to configure the deviation in percentage permissible of the load;	
	0.1 to 10%	When it exceeds the configured limit, it will start counting time to lower or raise the voltage. NOTE: The percentage of deviation must be greater than half of the corresponding voltage step of a TAP or there will be instability of the switch. In the example below, the deviation has to be set to a percentage greater than 0.5% Voltage Step = 140V Desired Voltage at Load = 13,200 V Deviation > (140 / 13200) / 2 > 0.5% NOTE: <u>This menu is available only with the timing set to linear and reverse.</u>	
Compensation Conf.			→ Menu to configure the command delay time for the switch;
	T. Subsequent		→ Menu to configure the subsequent wait time for the command to be repeated;
		0 to 30 sec	Command retries wait time for the switch, if one switch was not sufficient for the voltage to stay within the permissible deviation
T. Current		→ Menu to configure the subsequent wait time for the command to be repeated;	
	0 to 180 sec	Delay time for the voltage lowering command after detecting a voltage deviation. NOTE: <u>This menu is only available for timing configured as linear and reverse.</u>	

Menu	Parameter	Variable	Description	
Compensation Conf.	T. Descend		→ Menu to configure the command delay time for the switch to lower the voltage;	
		0 to 180 sec	Delay time for the command to lower the voltage after detecting a voltage deviation; <u>NOTE: This menu is only available for timing configured as linear and reverse.</u>	
	H. Calendar.		→ Menu to enable and/or disable the set of regulation by day and time of entry and exit; <u>NOTE: When the regulation set is disabled for entry by day and time, the set will only be executed by commands from the RS485 Serial Network or by digital inputs;</u>	
		Yes	Enables regulation by the day and time of entry and exit configured in the set;	
		No	Disables the regulation by the day and time of entry and exit configured in the set;	
	Day Week		→ Menu to configure the mode with which the adjustment set will enter;	
		Daily	Executes the set setting all two within the configured start and end time;	
		Monday	Selects Monday for the regulation set;	
		Tuesday	Selects Tuesday for the regulation set;	
		Wednesday	Selects Wednesday for the regulation set;	
		Thursday	Selects Thursday for the regulation set;	
		Friday	Selects Friday for the set of regulations;	
		Saturday	Selects Saturday for the regulation set;	
Sunday	Selects Sunday for the regulation set;			

→ Setup menu available when timing type is set to **Steps**

Menu	Parameter	Variable	Description
Step of Temporiza. 1	→ Menu to set the timing step parameters 1. <i>Option used when the Timing type is set to Step;</i>		
		→ Submenu to configure the deviation from step 1 in permissible percentage in the load;	
	Detour	0 to 10%	<p>The DVR has three configurable and independent bypass levels to raise or lower the voltage. When it exceeds the configured limit, the time to lower or raise the voltage will start.</p> <p>NOTE.1: <u>The percentage of deviation of step 1 must be less than the percentage of deviation of steps 2 and 3. The percentage of deviation from step 2 must also be less than the deviation from step 3.</u></p> <p>Example: Step deviation 1 = 4% Step deviation 2 = 7% Step deviation 3 = 10%</p> <p>NOTE.2: <u>The deviation percentage of step 1 must be greater than half of the corresponding voltage step of a TAP or there will be instability of the switch.</u></p> <p>In the example below, the deviation from step 1 has to be set to a percentage greater than 0.5% Voltage step = 140 V Desired voltage at load = 13.2 kV Deviation > (140 / 13200) / 2 > 0.5%</p> <p>NOTE.3: <u>This menu is available only with the timing set as a step.</u></p>
		→ Submenu to configure the delay time for the command to increase the voltage;	
	T. Current	0 to 180 sec	Step 1 (seconds) time of command delay for the switch to increase the voltage after detecting voltage deviation
		→ Submenu to configure the delay time for the command to lower the voltage;	
T. Descend	0 to 180 sec	Step 1 (seconds) time of command delay for the switch to lower the voltage after detecting voltage deviation.	

→ Setup menu available when timing type is set to **Steps**

Menu	Parameter	Variable	Description
Step of Temporiza. 2	→ Menu to set the timing step parameters 1. <i>Option used when the Timing type is set to Step;</i>		
	Detour		→ Submenu to configure the deviation from step 1 in permissible percentage in the load;
		OFF	Disables step 2;
		0 to 10%	The DVR has three configurable and independent bypass levels to raise or lower the voltage. When it exceeds the configured limit, the time to lower or raise the voltage will start. NOTE 1: <u>The percentage deviation of step 2 must be greater than the percentage of deviation of steps 1 and less than step 3.</u> Example: Step deviation 1 = 4% Step deviation 2 = 7% Step deviation 3 = 10%
	T. Current		→ Submenu to configure the delay time for the command to increase the voltage;
		0 to 180 sec	Step time 2 (seconds) of command delay for the switch to increase the voltage after detecting voltage deviation
	T. Descend		→ Submenu to configure the delay time for the command to lower the voltage;
		0 to 180 sec	Step time 2 (seconds) of command delay for the switch to lower the voltage after detecting voltage deviation.

→ Setup menu available when timing type is set to **Steps**

Menu	Parameter	Variable	Description
Step of Temporiza. 3	→ Menu to configure the timing step parameters 3. <i>Option used when the Timing type is set to Step;</i>		
	Detour	→ Submenu to configure the deviation of step 3 in percentage permissible in the load;	
		OFF	Disables step 3;
		0 to 10%	The DVR has three configurable and independent bypass levels to raise or lower the voltage. When it exceeds the configured limit, the time to lower or raise the voltage will start. NOTE.1: <u>The percentage of deviation of step 3 must be greater than the percentage of deviation of steps 1 and 2.</u> Example: Step deviation 1 = 4% Step deviation 2 = 7% Step deviation 3 = 10%
	T. Current	→ Submenu to configure the delay time for the command to increase the voltage;	
		0 to 180 sec	Step Time 3 (seconds) of command delay for the switch to increase the voltage after detecting voltage drift
T. Descend	→ Submenu to configure the delay time for the command to lower the voltage;		
	0 to 180 sec	Step time 3 (seconds) of command delay for the switch to lower the voltage after detecting voltage drift.	

MENU TRAF0

The TRAF0 menu is a configuration menu for the Transformer parameters and has the following Submenus:

- Reading Phase
- Color. Trafo
- TP Ratio
- TC Ratio

To access the menu with the display in reading mode. Press the **SET** key the display will present at the bottom a menu screen, with the **▶** key navigate to the **trafo** menu, press the **SET** key.

The **Trafo** menu has a password for your navigation, soon after pressing the SET key, a four-digit number will appear on the display, "password reminder" at the top and in the center **0000**. Use the **▲** or **▼** key to change the digits, to confirm the chosen number and move to the next number press the **▶** key, to return to the previous number press the **◀** key. Confirming the four digits press the SET key, if the password is correct, you will enter the configuration menu showing the configuration options. If the password is incorrect, an "incorrect password" message will appear at the bottom of the display and will show **0000** again.

After entering the password, the DVR will only ask for the password again when it returns to its measurement indication screen, if you continue to make configuration in other menus that have a password, the DVR will not ask for the password again.

The manufacturing password of the DVR is 0000. In case of loss or forgetfulness of the password, please contact Electron do Brasil informing the password reminder.

To navigate the setup menu using the **▲▼** keys. To enter the desired option press the SET or **▶** key, to change the value of the variables use the **▲▼** keys and press the SET key to confirm the change, to cancel the operation press the **◀** key. Automatically the variable will return its previous value.

Menu	Parameter	Variable	Description	
Reading phase	→ Menu to enable and/or disable the CT and TP reading phases;			
	TP Phases Attn:	→ Submenu to enable and/or disable voltage reading in phases A, B, or C.		
		OFF	Disables the voltage reading of the corresponding phase;	
	TC Phases Attn:	ON	Enables voltage reading of the corresponding phase;	
		→ Submenu to enable and/or disable voltage reading in phases A, B, or C.		
		OFF	Disables the voltage reading of the corresponding phase;	
Color. Enr. 1/2/3	---	ON	Enables voltage reading of the corresponding phase;	
	→ Menu to set the rated current of the CT transformer of phases A, B, and C.			
TP Ratio Attn:	---	0.001 to 9.999KA	Value in KA of the winding that will be monitored. Example: <u>Winding Current with nominal load: 0.95 KA.</u>	
	→ Menu to configure the TP transform ratio of Phase A, B, and C;			
TC A/B/C Ratio	---	1 to 9999	Value in KA of the winding that will be monitored. Example: TP=13800V/115V=120V (TP Ratio 120)	
	→ Menu to configure the CT transform ratio of Phase A, B, and C;			
	---	1 to 9999	Value of the CT transform ratio of each winding that will be monitored. Example: 950/5 = 190 A (TC Ratio 190 A)	

MENU SWITCHING

The menu **switches**. is a configuration menu for switch parameters and has the following Submenus:

To access the menu **switch**. with the display in reading mode. Press the **SET key** and the display will present a menu screen at the bottom, with the **▶** key navigate to the switch menu., press the **SET key**.

The menu **switches**. With the display in reading display mode. Press the **SET key** and the display will present a menu screen at the bottom, with the **▶** key navigate to the switch menu., press the **SET key**.

The **commut** menu has a password for your navigation, soon after pressing the SET key, a four-digit number will appear on the display, "password reminder" at the top and in the center **0000**. Use the **▲** or **▼** key to change the digits, to confirm the chosen number and move to the next number press the **▶** key, to return to the previous number press the **◀** key. Confirming the four digits press the SET key, if the password is correct, you will enter the configuration menu showing the configuration options. If the password is incorrect, an "incorrect password" message will appear at the bottom of the display and will show **0000** again.

The manufacturing password of the DVR is 0000. In case of loss or forgetfulness of the password, please contact Electron do Brasil informing the password reminder.

To navigate the setup menu using the **▲▼** keys. To enter the desired option press the SET or **▶** key, to change the value of the variables use the **▲▼** keys and press the SET key to confirm the change, to cancel the operation press the **◀** key. Automatically the variable will return its previous value.

Menu	Parameter	Variable	Description
T. Switching	→ Menu to configure the Switch Switching time.		
	---	1 to 100 s	Time required for the entire switching process, from the command to the end of execution. If switching does not occur within this time, failure and switching will occur;
Crown Reading	→ Menu to Enable and/or disable the reading of the Potentiometric Crown.		
	---	Yes	Enables the reading of the Potentiometric Crown;
		No	Disables the reading of the Potentiometric Crown;
Step	→ Menu to configure the resistive pitch of the Potentiometric Crown;		
	---	4.7 to 100	Resistance value of the resistive pitch of the Potentiometric crown;
1st Position	→ Menu to configure the initialization mode of the Potentiometric Crown reading;		
	---	0 to 100	<ul style="list-style-type: none"> Starts the indication from position 0 Ω; Starts the indication from the step of the resistance of the Potentiometric Crown.
Indication	→ Menu to configure the TAP indication type.		
	---	A	TAP Position Indication in numeric mode;
		ALF	TAP Position Indication in alphanumeric mode;

Menu	Parameter	Variable	Description
Pos. Neutral	→ Menu to configure the initial TAP Position indication range;		
	---	OFF	Disables the TAP Position indication
		-50 to 50	When the position is neutral the DVR will display the letter N which will refer to the NEUTRAL Position
Pos. Initial	→ Menu to configure the initial TAP position indication range;		
	---	OFF	Disables the TAP Position indication
		-50 to 49	NOTE: <u>Configuration used in the initial range of the Analog Output.</u>
Pos. Final	→ Menu to configure the final TAP position indication range;		
		OFF	Disables the TAP Position indication
		-50 to 49	NOTE: <u>Configuration used in the final range of the Analog Output.</u>
Post Suc Error	→ Menu for choosing a successive command on the Switch in case of a timing error. NOTE: <u>Menu valid only if the Parallelism Control function is enabled;</u>		
	---	Bloq.	Blocks Command on the switch in case of failure;
		B. Ret.	Returns to the previous position and locks the switch in case of failure;
Pos. Intermediate	→ Menu to configure the middle position of the Switch. NOTE: <u>Menu valid only if there is no option for Potentiometric Crown;</u>		
	Status	→ Submenu to Enable and/or Disable the Middle Position option	
		NO	Disables the middle position option;
		YES	Enables the middle position option;
	No. of Operations	→ Submenu to set the number of operations of the middle position;	
1 to 10		Number of switches performed by the Switch.	
Pos. Intermediate1, 2, 3, 4 and 5	→ Menu to configure the middle position of the Switch. NOTE: <u>Menu valid only if there is no option for Potentiometric Crown;</u>		
	Status	→ Submenu to configure the intermediate starting position;	
		NO	Disables the middle position option;
		YES	Enables the middle position option;
	TAP Neutral	→ Submenu to configure the intermediate starting position;	
		-50 to 50	The intermediate Initial Position is calculated automatically, adding the Initial Position with the number of trades
	No. of Operations	→ Submenu to configure the number of trades of the middle position.	
1 to 10		Number of switches made by the Switch between the intermediate start position and the end position;	

The menu **commens.** is a switch command menu and has the following options:

- Rising Voltage
- Lower Voltage

To access the **commen.** with the display in reading mode. Press the **SET key** and the display will present a menu screen at the bottom, with the ► key navigate to the command menu., press the **SET key**.

The menu **commens.** has a password for your browsing, soon after pressing the SET key, a four-digit number will appear on the display, "password reminder" at the top and in the center **0000**. Use the ▲ or ▼ key to change the digits, to confirm the chosen number and move on to the next number press the ► key, to return to the previous number press the ◀ key. Confirming the four digits press the SET key, if the password is correct you will enter the configuration menu showing the configuration options. If the password is incorrect, an "incorrect password" message will appear at the bottom of the display and will show **0000 again**.

After entering the password, the DVR will only ask for the password again when it returns to its measurement indication screen, if you continue to make configuration in other menus that have a password, the DVR will not ask for the password again.

From the factory the DVR password is 0000. In case of loss or forgetfulness of the password, please contact Electron do Brasil informing the password reminder.

To navigate the setup menu using the ▲ ▼ keys. To enter the desired option press the SET or ► key, to change the value of the variables use the ▲ ▼ keys and press the SET key to confirm the change, to cancel the operation press the ◀ key. Automatically the variable will return its previous value.

Menu	Parameter	Variable	Description
			→ Menu to run the local command to raise voltage.
Rising Voltage	- - -	DISP INDI.	<p>Select the function on the Voltage Up display and press the SET key. When the operating mode is configured to accept local commands, the Voltage Up field will display DISP, indicating that the command is available. When the command is unavailable, INDI will be shown.</p> <p>NOTE 1: <u>The DVR only accepts local command when in the REGULA>>OP MODE MENU. is set to LOCAL or REMOTE/LOCAL.</u></p> <p>NOTE.2: <u>The DVR will not accept local command when in the REGULA>>OP MODE MENU. is set to AUTO or REMOTE, or the equipment is set to Parallelism network as Follower.</u></p>
			→ Menu to execute the local command to lower voltage.
Lower Voltage	- - -	DISP INDI.	<p>Select the function on the Voltage Up display and press the SET key. When the operating mode is configured to accept local commands, the Voltage Up field will display DISP, indicating that the command is available. When the command is unavailable, INDI will be shown.</p> <p>NOTE 1: <u>The DVR only accepts local command when in the REGULA>>OP MODE MENU. is set to LOCAL or REMOTE/LOCAL.</u></p> <p>NOTE.2: <u>The DVR will not accept local command when in the REGULA>>OP MODE MENU. is set to AUTO or REMOTE, or the equipment is set to Parallelism network as Follower.</u></p>

MAINTENANCE MENU

The **Maintenance** menu is a configuration menu for the switch's maintenance parameters and has the following submenus:

- Configures switch;
- Maintenance Alarm;
- Maintenance Record

The menu **commens.** is a switch command menu and has the following options:

- Rising Voltage
- Lower Voltage

To access the **comman.** with the display in reading mode. Press the **SET key** and the display will present a menu screen at the bottom, with the ► key navigate to the command menu., press the **SET key**.

The menu **commens.** has a password for your browsing, soon after pressing the SET key, a four-digit number will appear on the display, "password reminder" at the top and in the center **0000**. Use the ▲ or ▼ key to change the digits, to confirm the chosen number and move on to the next number press the ► key, to return to the previous number press the ◀ key. Confirming the four digits press the SET key, if the password is correct, you will enter the configuration menu showing the configuration options. If the password is incorrect, an "incorrect password" message will appear at the bottom of the display and will show **0000 again**.

After entering the password, the DVR will only ask for the password again when it returns to its measurement indication screen, if you continue to make configuration in other menus that have a password, the DVR will not ask for the password again.

*From the factory the DVR password is **0000**. In case of loss or forgetfulness of the password, please contact Electron do Brasil informing the password reminder.*

To navigate the setup menu using the ▲ ▼ keys. To enter the desired option, press the SET or ► key, to change the value of the variables use the ▲ ▼ keys and press the SET key to confirm the change, to cancel the operation press the ◀ key. Automatically the variable will return its previous value.

Menu	Parameter	Variable	Description	
Configures Switch	N. OP. Last Maint.		→ Submenu to edit the number of operations performed by the switch since the last maintenance; <u>Range from 0 to 16,000,000 million operations;</u>	
	N. TOTAL CDC OPERATIONS		→ Submenu to edit the total number of operations performed by the switch; <u>Range from 0 to 16,000,000 million operations;</u>	
	Sum I ² Last Maint.		→ Submenu to edit the sum of current interrupted by the squared switch since the last maintenance; <u>Range from 0.00 to 99999.99 KA;</u>	
	Total Sum I ²		→ Submenu for editing Sum of Current Interrupted by the Squared Switch; <u>Range from 0.00 to 99999.99 KA;</u>	
	Average Commutation			→ Submenu to edit or query the quantities of switching performed by the OLTC during the selected period. <u>NOTE: Range from 0 to 999999 operations</u>
		Daily		Sum of operations carried out per day;
		Weekly		Sum of operations carried out in the week;
		Monthly		Sum of operations carried out in the month;
		Quarterly		Sum of operations carried out in three months
		Biannual		Sum of operations carried out in six months;
	Total Sum I ²			→ Submenu to edit or query the sum of current squared interrupted by the OLTC during the selected period. <u>NOTE Range from 0 to 999999.9 KA</u>
		Daily		Sum of current performed per day;
		Weekly		Sum of current performed in the week;
		Monthly		Sum of current carried out in the month;
		Quarterly		Sum of current performed in three months
Biannual			Sum of current performed in six months;	
Hour Meter Switch			→ Submenu to check or edit the amount of time the switch is running;	
	Partial Hour Meter		Period elapsed after maintenance (Time, Day and Year);	
	Total Hour Meter		Total Switch Period (Hour, Day, and Year);	

Menu	Parameter	Variable	Description	
	N. OP. Last Maint.		→ Submenu to edit the number of operations performed by the switch since the last maintenance; Range from 0 to 16,000,000 million operations;	
	Sum I ² Last Maint.		→ Submenu to edit the sum of current interrupted by the squared switch since the last maintenance; Range from 0.00 to 99999.99 KA;	
	Base			→ Submenu to configure the base option for calculating the advance period;
		Total Operations		Average of operations performed, i.e., Number of operations divided by the Partial Hour Meter of the Switch
		Latest Operations		Number of actual operations performed during the selected period
	Number of Switches			→ Submenu to configure the base and advance period option for switch maintenance alarm by number of switches;
		Base		Days, Weeks, Months, Quarter, Semesters and Years for the activation of the Maintenance Alarm;
		N. Base		Number of days, Weeks, Months, Quarters, Semesters and Years for the activation of the Maintenance Alarm;
	Switched Color Sum			→ Submenu to configures the base and advance period option for switchgear maintenance alarm by sum of squared switching current.
		Base		Days, Weeks, Months, Quarter, Semesters and Years for the activation of the Maintenance Alarm;
		N. Base		Number of days, Weeks, Months, Quarters, Semesters and Years for the activation of the Maintenance Alarm;

Menu	Parameter	Variable	Description
Maintenance Record	→ Submenu to record Switch maintenance.		
		No	Returns to the previous menu without confirming maintenance;
		Yes	<ul style="list-style-type: none"> • Yes – Confirms that the switch has been serviced and makes the following changes to the registers listed below: • Registrar, Number of switches since the last maintenance: Resets and a new period begins. • Register, Sum of current squared since the last Maintenance.: Resets and starts a new period. • Register, Partial Hourmeter: Resets and starts a new period. • Logger, Maintenance History: Records the date and time of maintenance, number of commutations and sum of current switched squared.

MENU PARALLELISM

The Paral menu. is a configuration menu for the parallelism network parameters and has the following Submenus:

- Pair.;
- Topology;
- N. Bank;
- N. Trafo;
- EndTrafo;
- EndBanco;

To access the **Paral menu.** with the display in reading mode. Press the **SET key** and the display will present a menu screen at the bottom, with the ► key navigate to the **Paral menu.**, press the **SET key**.

The Paral menu. has a password for your navigation, soon after pressing the SET key, a four-digit number will appear on the display, "password reminder" at the top and in the center **0000**. Use the ▲ or ▼ key to change the digits, to confirm the chosen number and move on to the next number press the ► key, to return to the previous number press the ◀ key. Confirming the four digits press the SET key, if the password is correct, you will enter the configuration menu showing the configuration options. If the password is incorrect, an "incorrect password" message will appear at the bottom of the display and will show **0000** again.

After entering the password, the DVR will only ask for the password again when it returns to its measurement indication screen, if you continue to make configuration in other menus that have a password, the DVR will not ask for the password again.

From the factory the DVR password is 0000. In case of loss or forgetfulness of the password, please contact Electron do Brasil informing the password reminder.

To navigate the setup menu using the ▲▼ keys. To enter the desired option, press the SET or ► key, to change the value of the variables use the ▲▼ keys and press the SET key to confirm the change, to cancel the operation press the ◀ key. Automatically the variable will return its previous value.

Menu	Parameter	Variable	Description
Paral.	→ Submenu to configure the Parallelism control mode;		
	---	OFF	Disables Parallelism function;
		Slave	Equipment parameterized in Slave mode;
		Master	Equipment parameterized in Master mode;
		Individual. B	Equipment in individual mode Bench. (Only in the Bank topology);
Individual. F	Equipment in individual Phase mode;		
N. Bank	→ Submenu to select the type of topology of the Parallelism network;		
	---	3 Phases	Network in Three-Phase Transformers <i>NOTE: Each Phase represents a single-phase transformer</i>
Bank		Network in Banco do Transformador;	
N. Trafo.	→ Submenu to configure the number of equipment in the Parallelism control network		
	---	1 to 31	<i>Menu available when the equipment is configured as Master and Network Topology as 3 Phases.</i>
EndTrafo 1	→ Menu to configure the address of the equipment in the Parallelism control network.		
	---	Off	Disables Trafo address 1;
On		Enable Trafo address 1;	
EndTrafo 2	---	Off	Disables Trafo 2 address;
		On	Enable Trafo 2 address;
Bench End XW.	→ Menu to configure the Slave or Follower Status in the Parallelism Control network, when configured as Transformer Bank.		
	1B, 1C 2A, 2B, 2C, 3A, ..., 9A, 9B and 9C	ON	Address of the Slave or follower in the Parallelism Enabled network.
		OFF	Address of the Slave or follower in the Parallelism Disabled network. <i>NOTE: Menu available when the equipment is set to Master. And "Bank" network topology. The addresses of the slaves or followers will be represented by the letter X and the bank phase by the letter W.</i>
End.Trafo X	→ Menu to configure the Slave or Followed Status in the Parallelism Control network, when configured as three-phase.		
	1 to 31	ON	Address of the Slave or follower in the Parallelism Enabled network.
		OFF	Address of the Slave or follower in the Parallelism Disabled network. <i>NOTE: Menu available when the equipment is configured as Master. and "3 Phase" network topology. The addresses of the slaves or followers will be represented by the letter X.</i>

IMPORTANT RECOMMENDATIONS

Before putting the equipment into operation, check the following recommendations:

1. All sensors as well as equipment must be grounded.
2. Properly grounded sensors and power prevent malfunctions or damage in cases of disturbances, surges, and inductions in the equipment.
3. Use in the communication network (Rs485) resistors of 120 Ohms at the 2 ends of the transmission line (start and end) in order to generate the potential difference necessary for the correct operation of the communication network.
4. Only use with the DVR and the original accessories that come with the equipment (TC Split core), as they have been rigorously tested together to ensure maximum efficiency and performance in the operation of the set.
5. Do not use the Regulator directly on the SUN, whenever it is installed in the field it is important to have a panel with smoked glass, in order to filter the ultraviolet rays that attack the front polycarbonate, in this way the life of the equipment will be prolonged.

IMPORTANT RECOMMENDATIONS CABLING

Recommended Cabling for connection (NBR-5410 and NBR-14039 Standards)		
Connection	Material	Quality
Grounding	NU Copper	High Electrical Conductivity.
	Tinned Copper	Corrosion resistance.
	Copper Tape	Lightning Protection.
	Grounding Mesh	Uniform fault current distribution.
	Grounding Rod	Creates a path of Low resistance to the earth.
RS-485 Communication	Belden 9841 (24AWG)	Twisted pair, shielded and Low Capacitance.
	Alpha Wire (22AWG)	
Feeding	EPR	Resistance to heat, humidity, chemical agents and withstand up to 90°C.
	XLPE	
Sensors	PT-100 Shielded (3x24 AWG) - Electron	Mechanical resistance and noise protection.
Relay Output	Shielded Multi-Way Cable	Mechanical resistance and noise protection.

Cabling Recommended for connecting current inputs/outputs					
Connection	Material	Range	Impedance	Distance	Minimum Gauge
Analog Outputs / TC / Tap Inputs	Shielded Multi-Way Cable	0...1mA	8kΩ	<100m	0.14 to 0.25mm ²
				>100m	0.35 to 0.5mm ²
		0...5mA	1.6kΩ	<100m	0.2 to 0.35mm ²
				>100m	0.5 to 0.75mm ²
		0...10mA	800Ω	<100m	0.25 to 0.5mm ²
				>100m	0.75 to 1.0mm ²
		0...20mA	400Ω	<100m	0.5 to 0.75mm ²
				>100m	1.0 to 1.5mm ²
		4...20mA	400Ω	<100m	0.5 to 0.75mm ²
				>100m	1.0 to 1.5mm ²

Table 2 – Cabling Recommendation

WARRANTY TERM

The DVR Electron has a warranty period of two years from the date of sale stated on the invoice, with coverage for any manufacturing defects that make it unsuitable or unsuitable for the applications it is intended for.

Disclaimer of Warranty:

The warranty does not cover transportation expenses for technical assistance, freight and insurance for shipment of a product with evidence of defect or malfunction. The following events are also not covered: Natural wear and tear of parts due to continuous and frequent use, damage to the outside caused by falls or improper packaging; attempt to repair/break a seal with damage caused by persons not authorized by Electron and in disagreement with the instructions that are part of the technical description.

Loss of Warranty:

The product will automatically lose its warranty when:

- The instructions for use and assembly contained in this manual and the installation procedures contained in the NBR 5410 Standard are not observed;
- Subjected to conditions outside the limits specified in the respective technical descriptions.
- Tampered with or repaired by a person other than Electron's technical staff;
- The damage is caused by a drop or impact;
- Infiltration of water or any other liquid occurs;
- Overload occurs that causes degradation of the components and parts of the product.

Use of the Warranty:

To enjoy this warranty, the customer must send the product to Electron along with a copy of the purchase invoice properly packaged so that there is no damage in transport. For emergency care, it is recommended to send as much information as possible regarding the defect detected. This will be analyzed and subjected to full functional tests.

The analysis of the product and its eventual maintenance will only be carried out by the technical team of Electron do Brasil at its headquarters.

Available for Downloads on the Website:

<http://www.electron.com.br/downloads/artigos-tecnicos/>