



MASTERTEMP

Catalogue

INDEX

INDEX	1
INTRODUCTION.....	2
KEY FEATURES	3
TECHNICAL DATA	5
TYPE TRIALS MET.....	6
OPERATION CHART TEMPERATURE DRIVE.....	7
OPERATION CHART LOADING DRIVE	8
PREVENTIVE MAINTENANCE	9
APPLICATION EXAMPLE.....	10
DIMENSIONS.....	11
CONNECTION DIAGRAMS.....	12
INSTALLATION ACCESSORIES.....	13
TCP CONVERTER.....	14
SPECIFICATION FOR ORDER	15
GETTING TO KNOW MASTERTEMP.....	16

INTRODUCTION

The **MASTERTEMP® Temperature Monitor** was developed to monitor the temperature of oil and up to 3 windings, control ventilation, protect power and distribution transformers (ANSI 49I and ANSI 49).

MASTERTEMP® was built in compliance with strict quality standards and uses state-of-the-art electronic components (SMD), its hardware was designed to withstand severe working conditions, all of this protected by an enclosure made of aluminum according to DIN IEC 61554 standard, these characteristics allow its installation directly in the panel of power transformers and reactors, on panels in the yard of power substations, offshore platforms and chemical industries.

As a signal input, **MASTERTEMP®** allows up to 2 (two) PT100 temperature sensors that can be configured for measurement of ambient and top oil temperature, commutator temperature and oil top with configurable alarm for the differential between them, lower tank temperature and oil top temperature or 2 points at the top of the oil for measurement redundancy and backup in case of loss of one of the sensors. It also has 3 (three) inputs for measuring the current coming from the Thermal Imaging CT to calculate the temperature of the windings using a precision transducer type TC Split core.

For remote transmission of these quantities, **MASTERTEMP®** has 5 (five) fully configurable analog outputs that can transmit any of the measured and or calculated quantities; oil temperatures, winding temperature, current in the primary of the windings, current in the secondary of the windings, percentage loading of the windings, differential of sensor temperature 1 and 2 in a standard of 0 to 1 mA, 0 to 5 mA, 0 to 10 mA, 0 to 20 mA, or 4 to 20 mA.

For the SCADA system or specialist software, all measured quantities, calculations and configuration parameters, in addition to the engineering models that are available in **MASTERTEMP®**, can be accessed through a digital output (RS485) with standard protocols such as Modbus RTU and DNP 3 (L2) chosen by the user in the equipment configuration menu, including remote control of drives in real time.

For alarm indication and thermal protection, the **MASTERTEMP®** has 13 isolated, potential-free trigger relays with configurable setpoints for alarms and shutdowns by Oil and Winding temperature levels, temperature differential alarms and sensor failures and activation of the 1st, 2nd and 3rd ventilation group that can also be triggered through the transformer load percentage and 1 auxiliary relay that is configurable by the user to the activation by any of the measured values.

KEY FEATURES

HUMAN MACHINE INTERFACE (HMI)

- OLED **display** with a graphic capacity of 128 x 64 pixels, with contrast adjustment and inversion of background colors and letters, readable in any lighting condition, including directly exposed to the sun.
- Stand-by IPD (Intelligent Presence Detector) **function** that detects the user's presence and automatically lights up the high-resolution OLED display. This function increases the useful life of the equipment's display, providing a reduction in internal energy consumption and extending the useful life of the entire electronic circuit. The user just needs to approach 1.5 meters away from the equipment and the sensor will detect its presence, and the OLED display will automatically turn on. This function is factory default, however, the user can disable it in the "Configuration" menu.
- Main screen with simultaneous indication of 5 monitored quantities and with the possibility of displaying the selected quantities in SCAN mode on the first line;
- Clock with HMS indication, in case of power outage and or power supply does not lose settings for up to 240 hours, uses super-capacitor for high operating temperatures and never requires replacement;
- 5 keys for navigation;
- 14 Led's on the Front that allow identification even at a distance from the existence of activated output relays;
- Indication of events and faults in writing on the display (Annunciator) and description of the relays that are triggered;
- Intuitive menus for configuration, indication, activations, maintenance and transformer parameters, protected by access password and in 2 languages (Portuguese and English);
- Consultation in the menu of indications of the maximum temperatures reached by the sensors;
- Consult the menu of indications of the operating time of each ventilation group;
- Consultation in the indication menu of the final gradient of each transformer winding;
- Consultation in the indication menu of the percentage load of each transformer winding;
- Consultation in the menu of indications of the currents measured by the external CT external CT (Split core / Clamp);
- Consultation in the menu of indications of the currents in the transformer winding (calculated value);
- Consultation in the loading indication menu of each transformer winding (calculated value);
- Consultation in the menu of indications of the loss of life of each winding and the remaining life of each winding;

ENGINEERING ALGORITHMS FOR MONITORING

- Thermal Image Calculation (Hot Spot) based on IEC 60076-7, IEEE C57.91 and NBR 5356-7:2017 standards;
- Calculation of transformer loading percentage display;
- Calculation of the Final Temperature Gradient for the current load (oil-winding);
- Selectable Insulation life loss calculation for Kraft (55°C), Thermo Stabilized (65°C) and Nomex (95°C) based on Arrhenius' theory, and indication of remaining insulation life in hours and days.
- Calculation of the temperature differential between two PT100 sensors for monitoring switch defects or monitoring cooling efficiency.
- Monitoring of the operating time of the fans (Hour meter) with programmable alarm for maintenance warning;

DIGITAL COMMUNICATION PORTS AND PROTOCOLS

- Front USB 2.0 communication port with Type-A connector for downloading and uploading settings via **USEEASY software**;
- 2-wire RS485 Digital Output (ANSI/TIA/EIA-485-A) with 2 protocols available, **Modbus RTU** and **DNP3** (Level2) for remote monitoring through SCADA software and access to all measured parameters and activation of digital outputs;
- Auto Baud Rate from 2,400 to 57,600 bps (Automatically Detects Communication Network Speed);

DATA LOGGER AND DATA STORAGE

- Front slot for 8Gb Micro SD card that allows storage for up to 10 years of data measured and calculated in Mastertemp;
- Storage by time and variation of measurements, with the recording interval being configurable between 5 and 180 minutes, and the variation value that must be disregarded between 1°C to 10°C and 100 mA at 1 A;
- Internal non-volatile memory that stores the maximum temperatures reached in the PT100 sensors and transformer windings;

SENSOR INPUT AND MEASUREMENTS

- 3 Permanent current measurement inputs from 0 to 10 Amperes for the calculation of thermal image, uses external CT (Split Core / Clamp) of the type and current transducer that provides in the secondary a standard analog output of 2 wires at 4 20 mA amplified that allows it to be installed at a distance of up to 500 meters from the monitor without loss of precision (1%) and signal quality;
- 2 inputs for temperature measurement with PT100 type sensor 3 wires (EM 60751 – DIN 43760) for measurement range from -50°C to 250°C with accuracy of 0.25% (FS) and indication of 1 decimal place, one of the inputs is mandatorily used for temperature measurement of the top of the Transformer oil and the other can be configured to:
 1. Commutator oil temperature measurement with configurable differential alarm for detection of commutator defects.
 2. Measurement of the Lower Temperature of the Tank or Radiator Outlet with indication of the differential between the temperature of the top of the oil, used to measure the efficiency of the transformer cooling system;
 3. Measurement of a second point of Temperature from the top of the transformer oil with indication of the average temperature between the two sensors and automatic backup in case of failure of one of the sensors;
 4. Ambient Temperature Measurement for use in the calculation of permissible load of the transformer;
 - 5.

DIGITAL RELAY OUTPUTS

- 1 Relay with 6 Ampere driving capacity for Alarm for High Oil Temperature NA – Normally Open (NC – Normally Closed on request);
- 3 Relays with 6 Ampere Driving Capacity for High Temperature Alarm of NA Winding – Normally Open (NC – Normally Closed on request);
- 1 Relay with 6 ampere driving capacity for High Temperature Shutdown of NA Oil – Normally Open (NC – Normally closed on request), with programmable delay timing from 0 to 20 minutes;
- 1 Relay with 6 ampere driving capacity for monitor fault signaling (Watchdog);
- 1 Relay with 6 ampere auxiliary driving capacity that can be programmed to be as alarms, shutdown or temperature differential;
- 3 Relays with a conduction capacity of 6 amperes for activation of ventilation or pump groups NO – Normally Open or NC – Normally Closed, with programmable hysteresis 0 to 30°C and timed interlock of 15 seconds;

TECHNICAL DATA

Transformer Temperature Monitor - MasterTemp	
Operating Voltage	48 to 265 Vdc/VAC 50/60 Hz (-20 % / +10 %)
Operating Temperature	-40 °C to 85 °C
Storage Temperature	-50 °C to 50 °C
Consumption	< 15 W
External source rated voltage for analog output	24 V DC / 2 A
Temperature Measurement Input	Up to 2 – PT100 Ohm at 0 °C at 3 wires (EN 60751 - DIN 43760)
Measurement Range	-50 to 250 °C
Current Measurement Input	Up to 3 Split-Core CTs from 0 to 10 A (True RMS)
Analog Output and Maximum Load Options	0 ... 1 mA - 8000 Ohms
	0 ... 5 mA - 1600 Ohms
	0 ... 10 mA - 800 Ohms
	0 ... 20 mA - 400 Ohms
	4 ... 20 mA - 400 Ohms
Maximum Error of Measurement Inputs	0.25% of end-of-scale
Maximum Analog Output Error	0.25% of end-of-scale
Relay Outputs	13 – Free of Potential
Maximum Switching Power	70 W / 250 VA
Maximum Switching Voltage	250 Vac/Dc
Maximum Driving Current	6 Amps
Serial Communication Port	RS-485 2-wire standard - (ANSI/TIA/EIA-485-A)
Communication Protocol	Modbus RTU and DNP 3 Level 2 (Slave)
Network Speed – Auto Baud Rate	2,400 to 57,600 bps
Front USB Port (configuration)	Micro-USB
IEC 61554 DIN Box (Cabinet)	98 x 98 x 98 mm – Aluminum
Fastening – steel clip	Flush Panel Mounting
Current Transformer - TC Split Core	
Output Signal and Maximum Load	4 to 20 mA – 400 Ohms
Measurement Range	0 to 10 A
Maximum Error of Measurement Inputs	1% of the end of the scale
Linearity	1% of the end of the scale
Operating Temperature	-40 to 85 °C

Table 1 – Technical data of the MasterTemp thermal protection relay.

TYPE TRIALS MET

- Applied Voltage (IEC 60255-5): 2kV / 60Hz / 1 min. (against land);
- Voltage Impulse (IEC 60255-5): 1.2/50 μ sec. / 5kV / 3 sec. and 3 sec. / 5 sec. Interval;
- Electrostatic Discharges (IEC 60255-22-2): Air mode = 8kV / Counted mode = 6 kV;
- Immunity to radiated electromagnetic disturbance (IEC61000-4-3): 80 to 1000 MHz / 10V/m;
- Immunity to Fast Electrical Transients (IEC60255-22-4): Input/Outputs=4KV/common. 2kV;
- Surge Immunity (IEC60255-22-5): phase/neutral 1kV, 5 per polar. (\pm) - phase-to-ground/neutral-to-ground 2kV, 5 per polar (\pm);
- Immunity to conducted Electromagnetic disturbances (IEC61000-4-6): 0.15 to 80 MHz / 10V/m;
- Climate Test (IEC60068-21-14): -40°C + 85°C / 72 hours;
- Vibration Resistance (IEC60255-21-1): 3 axes / 10 to 150Hz / 2G / 160min/axis;
- Vibration Response (IEC60255-21-1): 3-axis / 0.075mm-10 at 58 Hz / 1G from 58 to 150 Hz / 8min/axis;

OPERATION CHART AREA TEMPERATURE DRIVE

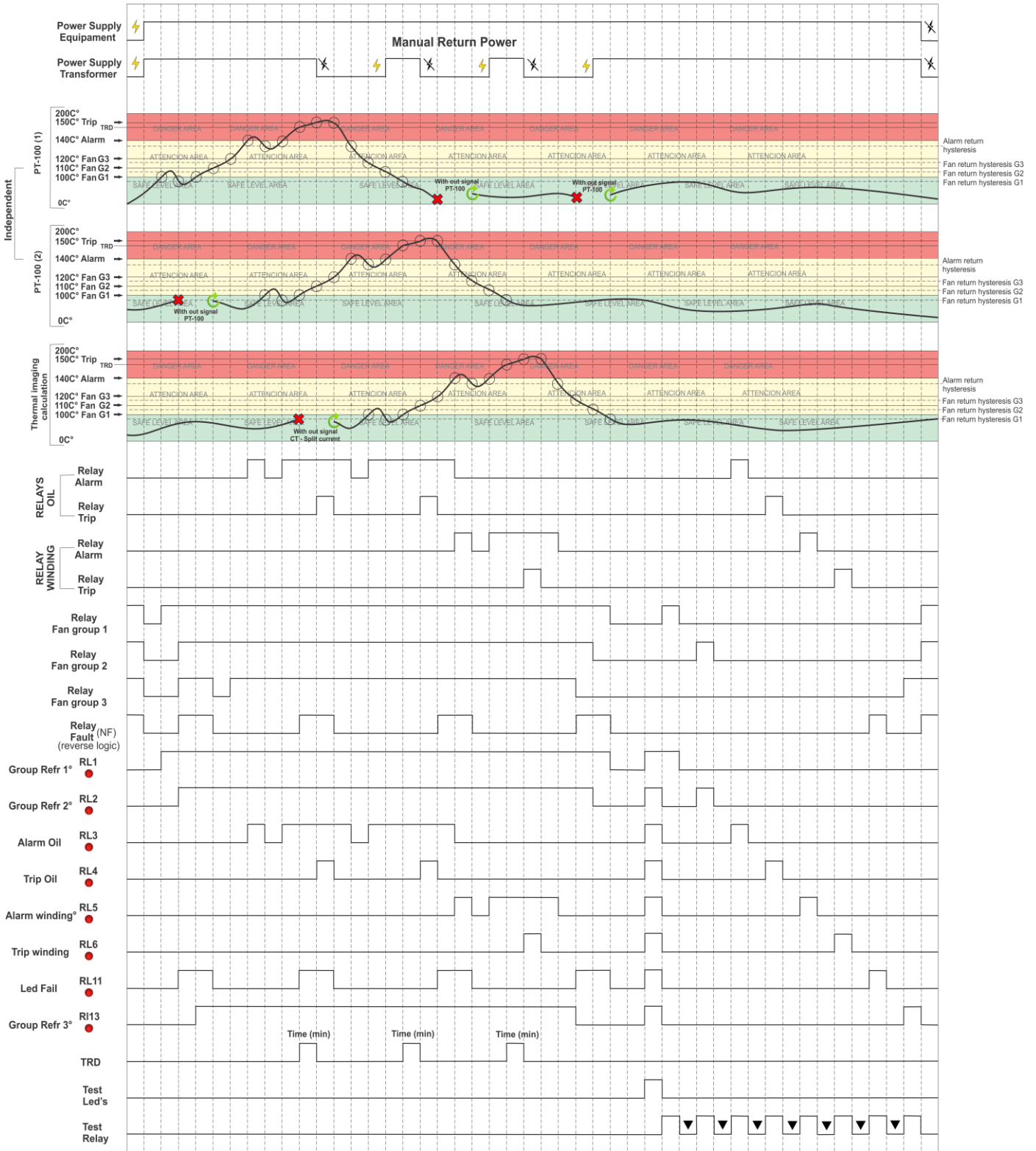

Table 2 – Operating chart, activation by temperature

OPERATION CHART LOADING DRIVE

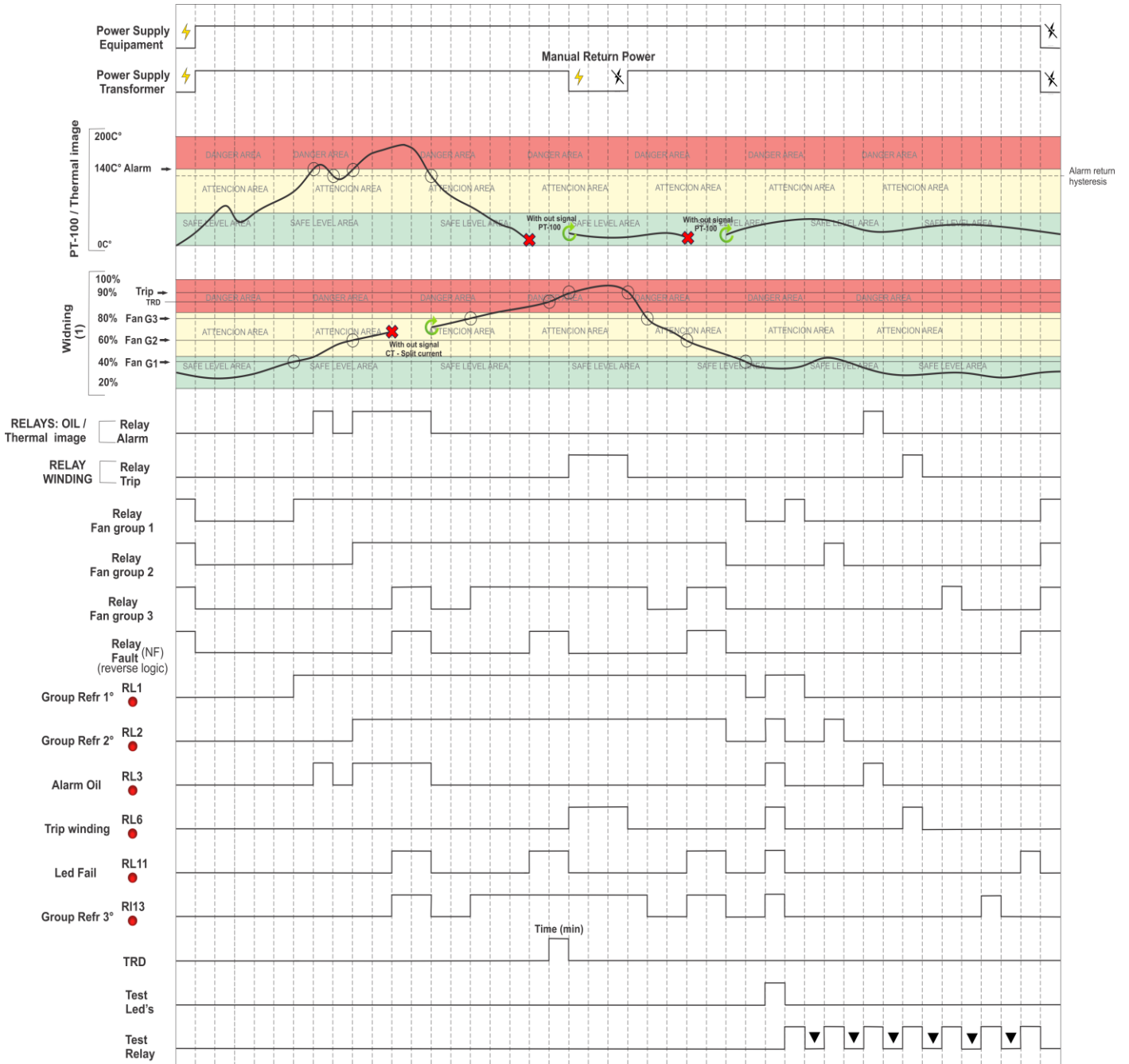

Table 3 – Operation chart, load drive

PREVENTIVE MAINTENANCE

PREVENTIVE AND CORRECTIVE MAINTENANCE							
Items to be checked preventively			Verification Frequency				Corrective action
SHARE	Verification Elements	ACTIVITIES	Every Month	Every 3 Months	Every 6 Months	Every 1 Year	When Needed
VERIFICATION	Fastening clip and snapping to the rail	Fixing to the panel door or panel bottom		X			Retightening, Fitting, Terminal Change, or Screw Change
	Terminal Blocks and Connector Comb	Attachment and attachment to equipment		X			
		Tightening of the screws in the fastening of the conductors		X			
	Sensors	Integrity / Positioning / Fastening			X		Replacement, repositioning and/or fixing of sensors
	Sensor well of oil transformers	Oil level in the well			X		Oil filling to indicated level
TESTS & MEASUREMENTS	Relays and Digital Outputs	Individual drive test			X		Forward to Electron do Brasil technical assistance
	LED's and Displays	Test LED's and display segments			X		
	Navigation buttons	Navigation test of the navigation buttons			X		
	Sensor Input	Gauge sensor inputs using a standard				X	
	Input voltage of equipment supply	Measure Supply Input Voltage			X		Override voltage input values according to equipment model
	RS-485 Communication Outputs	Communication and command testing in the supervisory system			X		Forward to Electron do Brasil technical assistance
	Milliampere Current Signal Inputs	Measure, compare and measure input signal in passive and/or active mode			X		
	Signal Outputs of milliampere current	Measure, compare and measure input signal in passive and/or active mode			X		
CLEANING	Terminal blocks and connector comb and connection box	Debris, Impurities and Moisture	X				Cleaning with a dry cloth, compressed air and vacuum cleaner
	Aluminum Equipment Enclosure		X				
	Front of the Equipment Display		X				
 ATENÇÃO	<p>1 - Keeping the equipment within the ideal working temperature (50°C to 60°C) extends the useful life and avoids corrective maintenance.</p> <p>2 - The accumulation of dust and impurities in the facilities can cause short-circuiting and burning of equipment and sensors.</p> <p>3 - After 10 years of use, it is recommended to replace the equipment.</p>						

Table 4 – Preventive maintenance

APPLICATION EXAMPLE

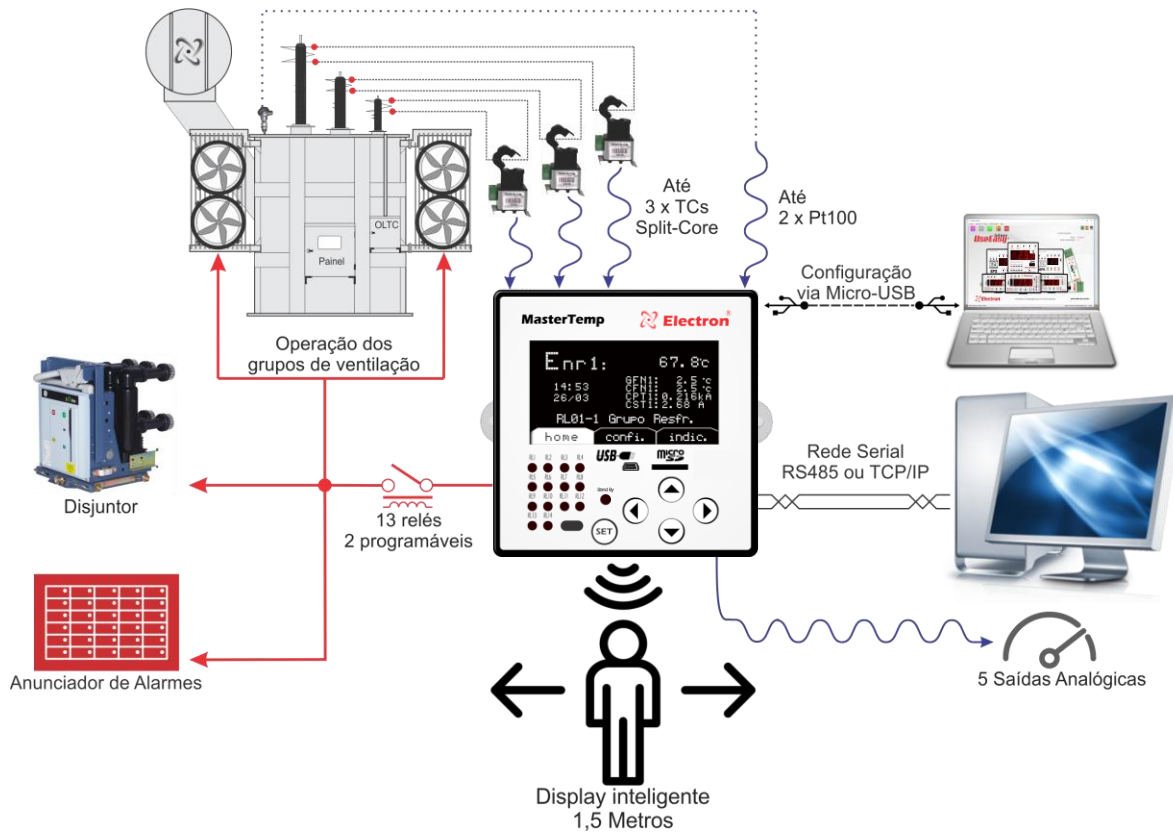

Fig. 1 – Illustrative example of MasterTemp applications

DIMENSIONS

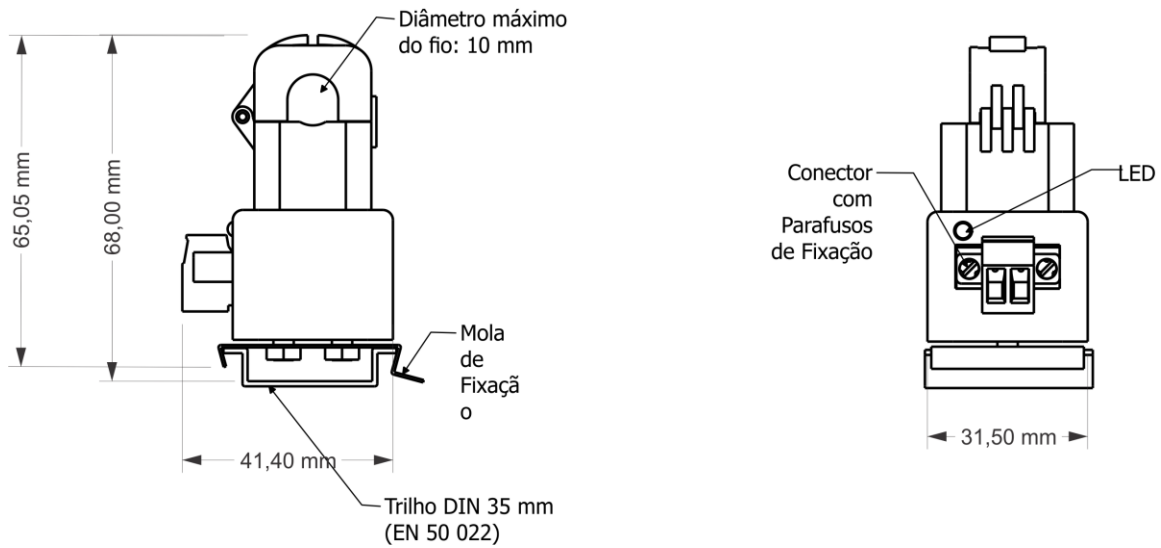

Fig. 2 – Dimensions of the TC-Splitcore

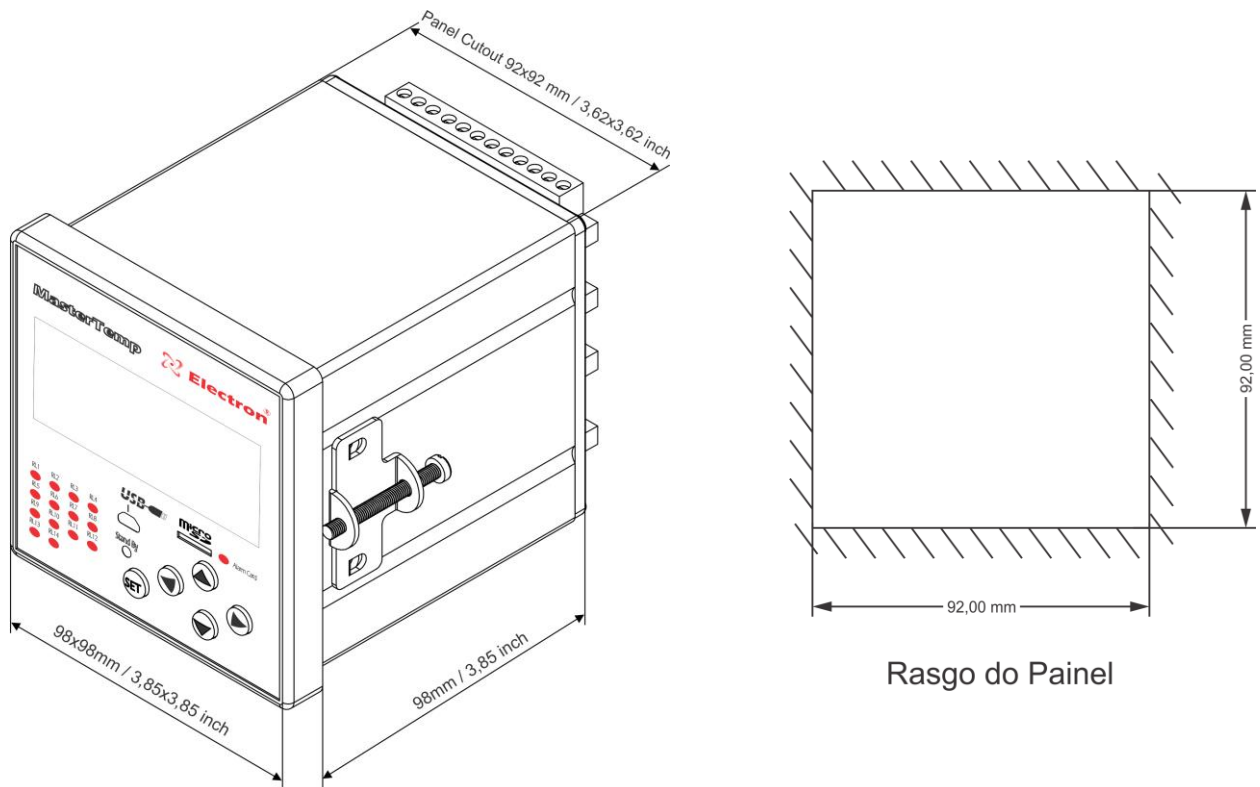

Fig. 3 – MasterTemp dimensions

CONNECTION DIAGRAMS



Diagrama para conexões de Indicadores Analógicos com fonte externa.

Fig. 3 – MasterTemp connection diagram

INSTALLATION ACCESSORIES

Electron do Brasil has a line of accessories that can be purchased together aiming to offer a complete solution to meet your application with practicality. We have listed some of the main accessories that can be used for Mastertemp operation.

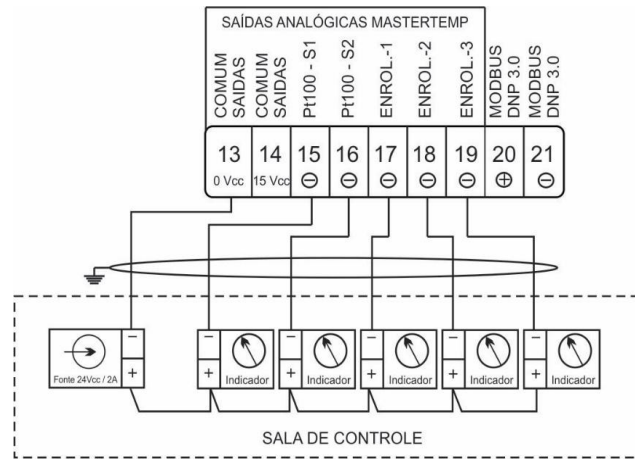
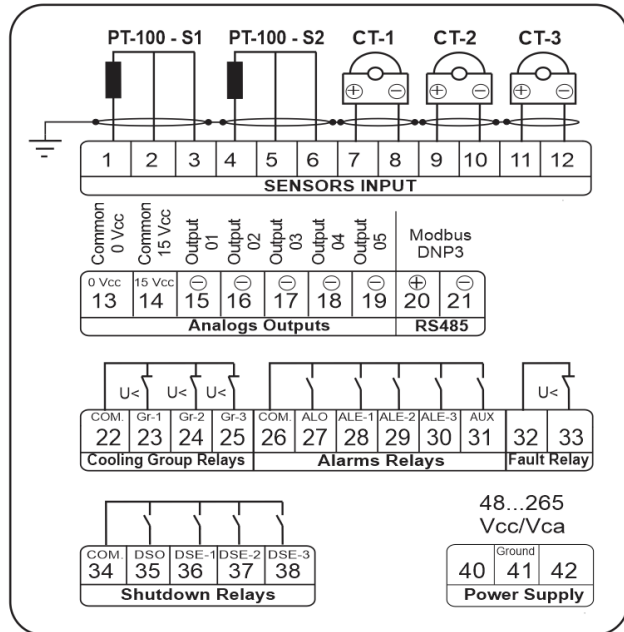
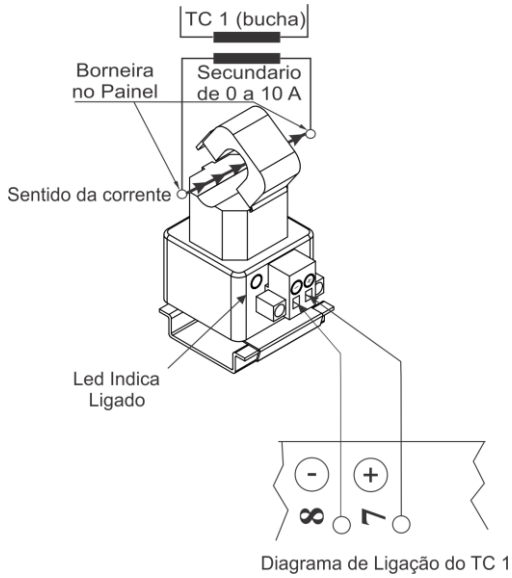

PT100 STE Temperature Sensor: This sensor is constructed with AISI-304 stainless steel bulb, injected aluminum head (IP 65) and adjustable gland with 3/4" and 1/2" BSP threads, or can be manufactured according to design. Its principle is to measure the variation of electrical resistance with temperature using the temperature coefficient of pure platinum (0.385 Ohm/K), according to IEC 751 (DIN 43760). Ideal for installations subject to weather, and electrical disturbances for temperature monitoring of transformers and machines that require high measurement accuracy in environments subjected to electrical noise and weathering. The PT100 3-wire sensor is widely used in the market, as the possibility of measurement error is greatly reduced due to the compensation principle of the third terminal of the sensor.

Electron PT100 STFE Temperature Sensor Page Link:
<https://electron.com.br/site/produtos/rtd-pt100/>



Double door panel for outdoor/outdoor use: Box for outdoor use with double port for mounting instruments, accessories and passing control wires and power of the power transformer. The external door contains a glass display with UV protection for viewing the quantities measured by the temperature monitor and the panel contains special paint that is resistant against weather and its degree of protection is IP 55, as per NBR IEC 60529:2017.

Dual Port Panel for Outdoor Use – IP 55 Page Link:
<https://electron.com.br/site/produtos/painel-para-uso-externo-ip55/>



Reference card for PT100 signal: This accessory was developed to verify the temperature value displayed by equipment with 3-wire PT100 RTD sensor input. It consists of precision resistors that send an equivalent fixed and constant resistance signal for selection between 3 different ranges, 0 °C (100 Ohms), 26 °C (110.9 Ohms) and 200 °C (175.86 Ohms).

Reference Card page link for PT100 signal:
<https://electron.com.br/site/produtos/>

TCP CONVERTER

Modbus TCP Slave / Modbus Master – Converter:



Fig. 3 – TCP Converter

Key features:

The HD67507 is a Modbus TCP Slave / Modbus Master converter.

It allows the following features:

- Triple isolation between serial – Power Supply, Serial – Ethernet, Power Supply – Ethernet.
- Ethernet 10Base-T/100Base-T, auto-detect for modbus TCP;
- For WI-FI version, access point, or client mode;
- Mountable on 35mm DIN rail;
- Wide power supply input range: 8... 24V AC or 12... 35V DC;
- Wide temperature range: -40°C / 85°C

SPECIFICATION FOR ORDER**MONITOR DE TEMPERATURA DIGITAL MASTERTEMP****MTTP -**

Medição de Corrente	
0	Sem TC split core
1	1 TC Splitcore
2	2 TC's Splitcore
3	3 TC's Splitcore

GETTING TO KNOW MASTERTEMP

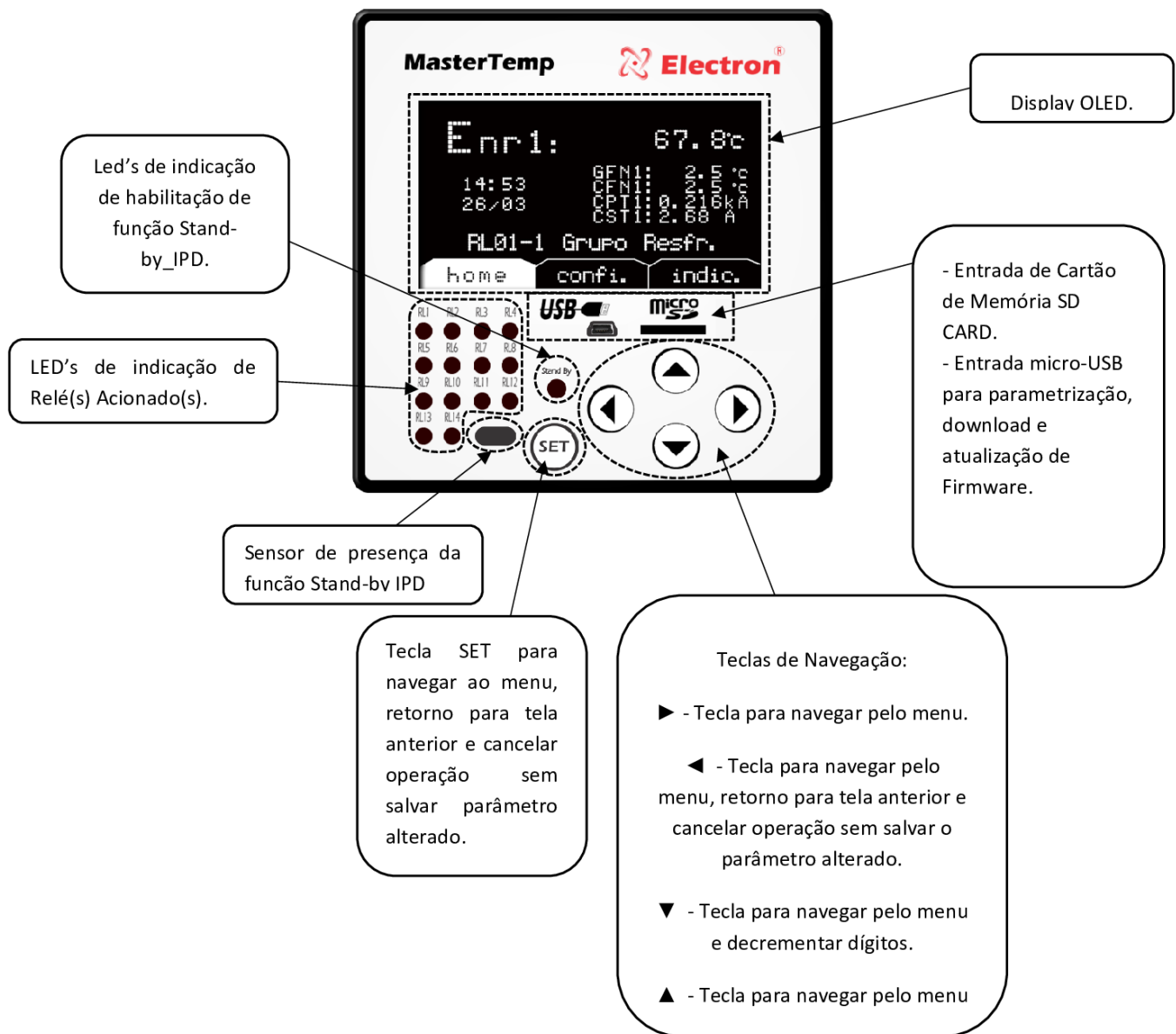

Fig. 5 – MasterTemp front