

Remote Terminal Unit – RTU

Manual

INDEX

INDEX	1
INTRODUCTION.....	2
APPLICATION EXAMPLE – POWER TRANSFORMERS IMMERSSED IN INSULATING OIL	4
APPLICATION EXAMPLE – OFFSHORE OIL RIG	4
APPLICATION EXAMPLE – DATACENTER	5
APPLICATION EXAMPLE – SOLAR POWER PLANT	5
APPLICATION EXAMPLE – AUTOMOTIVE INDUSTRIES	6
APPLICATION EXAMPLE – AGRICULTURAL SECTOR	6
SIGNAL PROCESSING – MAIN AND AUXILIARY MODULES.....	7
SIGNAL PROCESSING – INPUT MODULES (iNPUTS).....	8
SIGNAL PROCESSING – OUTPUT MODULES.....	8
PROCESSAMENTO DE SINAIS – MODULOS DEDICADOS PARA TRAFOS (INPUTS/OUTPUTS).....	8
SOURCE MODULE - PW	9
SOURCE MODULE CONNECTION DIAGRAMS – PW	10
PROCESSING MODULE – CPU	10
PROCESSING MODULE – CPU CONNECTION DIAGRAMS	11
SFP COMMUNICATION INTERFACE.....	13
DATA COMMUNICATION MODULE - DCM	13
PROCESSING MODULE CONNECTION DIAGRAMS – DCM.....	14
ANALOG INPUT MODULE - AI	15
RELAY DIGITAL OUTPUT MODULE – DO.....	15
ANALOG OUTPUT MODULE - AO.....	16
TEMPERATURE READING MODULE – RTD – PT100	17
DIGITAL INPUT MODULE - DI	17
MÓDULO de ENTRADA DIGITAL / ENTRADA PT-100 / LEITURA DE NÍVEL - DPN	18
DEDICATED RBM MODULE – MEMBRANE BAG RELAY	19
GENERAL TECHNICAL DATA	20
TYPE TRIALS MET	20
DIMENSIONS	20
SENSORS FOR APPLICATION WITH RTU	21
ATTACHMENT INSTRUCTIONS	22
ORDER SPECIFICATION	23
SFP TRANSCEIVER ORDER SPECIFICATION	25
TYPES OF SFP TRANSCEIVER CONNECTIONS	26
HOW TO CONNECT AND DISCONNECT MINI GBIC	27
DOWNLOAD AND INSTALLATION OF RTU SOFTWARE BY WINDOWS 10	28
CONFIGURING THE RTU VIA SOFTWARE	30
IMPORTANT RECOMMENDATIONS	36
WARRANTY TERM	36

INTRODUCTION

The Remote Terminal Unit (RTU) from Electron do Brasil is a microprocessed equipment with high capacity for data acquisition, monitoring, indication, control and supervision. This makes it a robust, versatile and configurable solution, with numerous application possibilities, due to its reliability and efficiency. The RTU is intended for the most diverse sectors.

- **ENERGIA**
 - Electrical Substations;
 - Hydroelectric Power Plants;
 - Solar Power Plants;
 - Wind Power Plants;
 - Green Hydrogen Plants (H2 Green);
 - Transformers and Power Transmission and Distribution;
 - Protection, Distribution and Control Panels;
- **ÓLEO E GÁS**
 - Fixed Oil Platforms;
 - Self-elevating;
 - Semi-submersible;
 - FPSO;
 - FPSO Mono column;
 - TLWP;
 - Navio Sonda;
- **TRANSPORTE**
 - Traffic Control;
 - Railroad Control;
 - Electric Trains and Trams;
- **CONSTRUÇÃO CIVIL**
 - Smart Building Management (BMS);
 - Monitoring and Control of Escalators;
 - Air Conditioning Monitoring and Control;
 - Elevator Monitoring and Control;
 - Lighting Monitoring and Control;
- **SANEAMENTO**
 - Monitoring and Control of Reservoir Level;
 - Pump Monitoring and Control;
 - Monitoring and Control of Signals and Sensors;

RTU offers many advantages in its implementation. The download and use of its software is free, didactic and easy to parameterize. The configuration of the modules is completely free, allowing the user to specify the product in a way that best meets their application.

The equipment can be configured to provide up to five communication ports for SCADA systems. Its programming logic is limitless. The RTU allows internet connection via MQTT Broker, enabling access to statuses and parameters through a web page, mobile application or pairing via Bluetooth.

The **RTU** is a modularly configurable equipment, that is, the number of modules must be specified to meet the application for which it is intended. The default configuration of the Electron RTU is:

- 1 Fonte Module (RTU-PW).
- 1 CPU Module (RTU-CPU).
- 1 Communication Module (RTU-DCM) (Optional).
- And up to 8 modules for processing Input/Output signals (DI, DO, AI, AO, PT-100, NPN/PNP) and/or Dedicated Modules.

The Power Module, **RTU-PW**, has a universal power supply with a range of 85 to 265 Vdc/Vac. It also has a relay output for Fault signaling (Watchdog) that will trigger when the RTU is not receiving a reliable signal from a signal connected to one of its inputs or when the equipment is not receiving power suficiente para operar. Oferece opção de Alimentação Auxiliar através de um contato de saída de 24 Vcc (2 Watts e 83 mA).

The CPU Module, **RTU-CPU**, has input for up to 3 SFP ports, 2 Ethernet in Bridge mode (ETH1 and ETH2) with **IEC61850** protocol and 1 RS485 serial, with Modbus RTU and DNP communication protocols, for the use of these ports it is necessary to use SFP base 100 Mb/s Transceiver with LC / SC and RJ45 type connectors. The RTU-CPU Module further contains 2 more RS-485 serial ports (ANSI/TIA/EIA-485-A) with the option to select between Modbus RTU and DNP 3.0 Level 2 communication protocols. It also offers the option of an input for optical fiber through ST type connectors that can be used to traffic the protocols integrated in it or to be used as communication between 2 Remote Connectors (RTU) that form an isolator and transducer of signals, one RTU works in Transmitter mode and the other in Receiver mode, both can be interconnected by a pair of multimode optical fiber for safe transmission over a distance between the RTU's of up to 3,000 meters, in this way it is possible to make the acquisition on site of a clean signal close to the generating source and transmit it remotely with high resolution and immunity to all types of signals, electrical noise and humidity, as well as free from being affected and/or damaged by lightning strikes. The RTU-CPU module has as an optional slot for micro-SD card (Datalogger) Class 10 (10mB/s) for data storage where all data can be stored and consulted later with generation of graphs and spreadsheets for analysis and decision making. Contains a front Micro USB port for parameterization software communication, **Useeasy™**.

The Data Communication Module, **RTU-DCM**, offers a wireless internet connection, where all data and status of variables, inputs and outputs, can be sent to a database and managed by an MQTT Broker. In this way, the user can access and consult the equipment whenever he wants and from wherever he is. The RTU contains the possibility of pairing via Bluetooth for communication and data consultation. The **RTU-DCM** module also offers the option of an RS-485 port in Slave or Master mode. The RS-485 Master port is designed according to the application requirements previously informed. In addition to offering a port for Ethernet TCP/IP for data communication via Ethernet. There is also an option for Micro SIM Card entry, which enables remote monitoring through the NBloT network using MQTT protocol.

Signal Input and Output modules, or I/O modules, provide many possibilities for data acquisition, monitoring, and control for various applications. It contains the standard modules for this product, which are Digital Input (**RTU-DI**), Digital Output (**RTU-DO**), Analog Input (**RTU-AI**), and Analog Output (**RTU-AO**), among others.... And we also have the option of dedicated modules, with more than one type of signal in the same module. Each RTU I/O Module contains up to 8 inputs or 8 outputs. Each module can be mounted from 1 to 8 slots which adds up to 64 IO's. The order in which each I/O module is selected per slot is fully configurable, i.e., you can specify the product in the best way and according to your needs. To consult all the signals of the input and output modules of Remota, see

Table 1, 2, 3 and 4.

The RTU is a compact equipment, built in extruded aluminum with electrostatic paint that protects the equipment against external chemical agents and the aluminum casing protects the electronic boards against noise and external disturbances in addition to being an excellent thermal dissipator that prolongs the life of the electronic components and fixing on DIN rail 35mm at the bottom of the panel.

APPLICATION EXAMPLE – POWER TRANSFORMERS IMMERSED IN INSULATING OIL

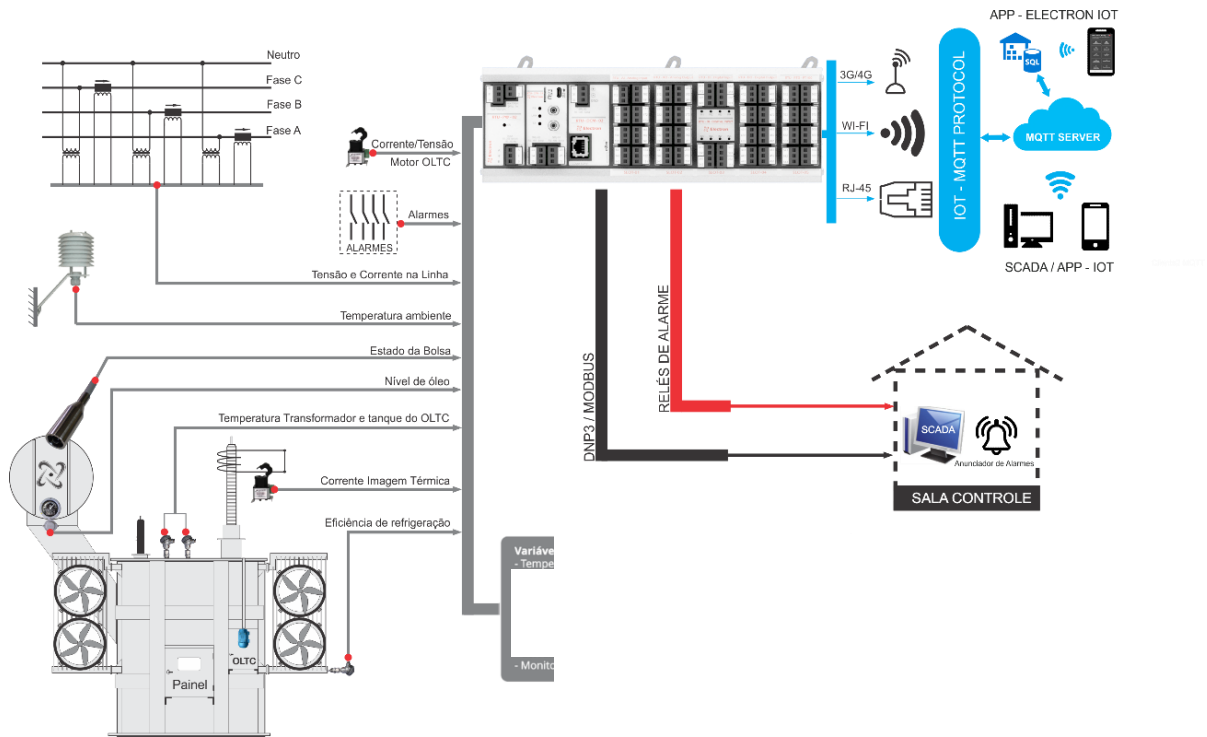

Figure 1 - Monitoring of Power Transformer immersed in insulating liquid.

APPLICATION EXAMPLE – OFFSHORE OIL RIG

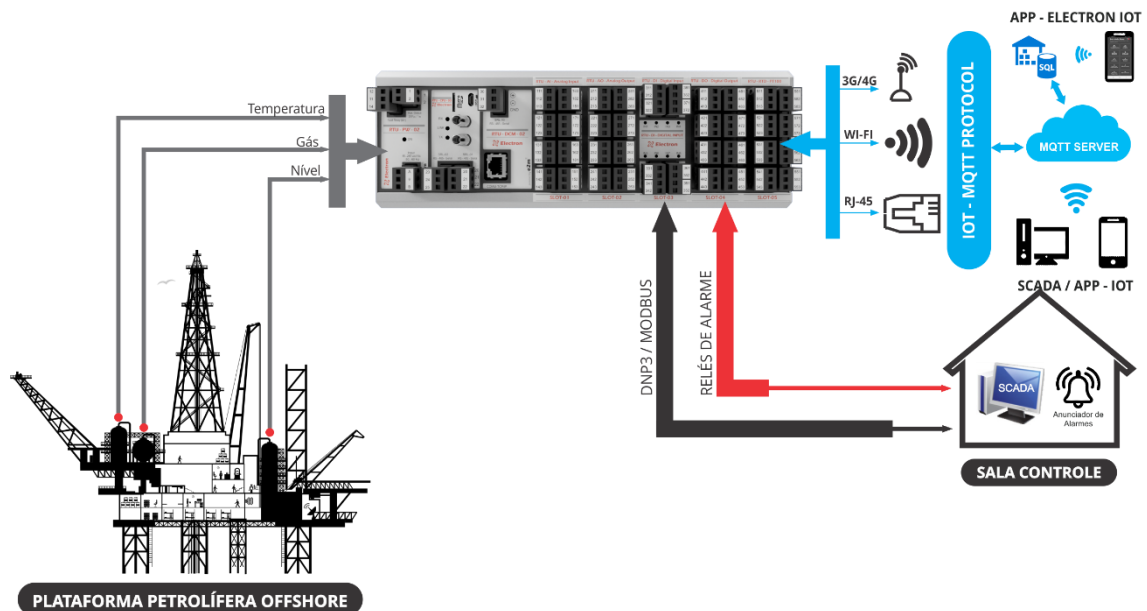

Figure 2 - Monitoring and Protection on Off-Shore Oil Platforms

APPLICATION EXAMPLE – DATACENTER



Figura 3 - Proteção e monitoramento de Data Centers.

APPLICATION EXAMPLE – SOLAR POWER PLANT

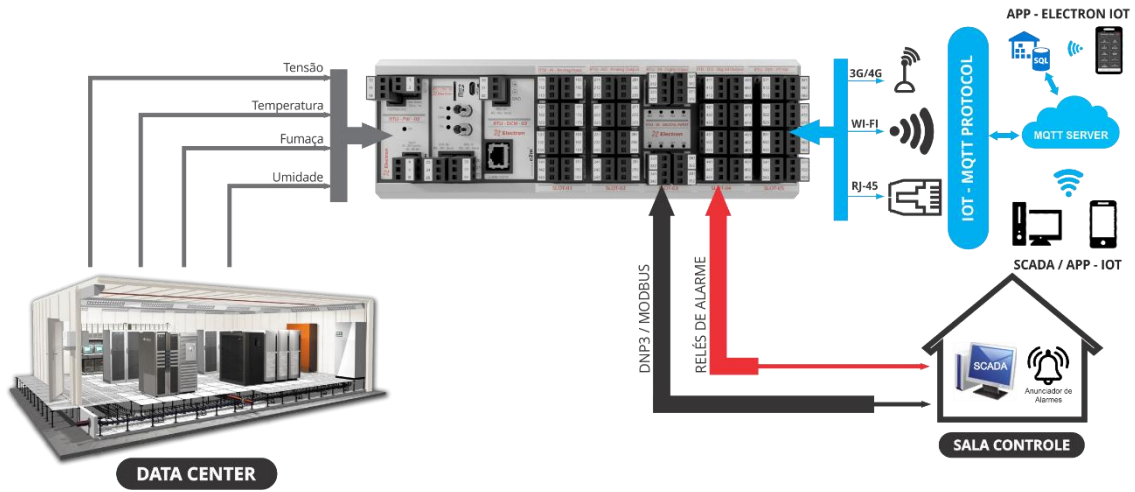
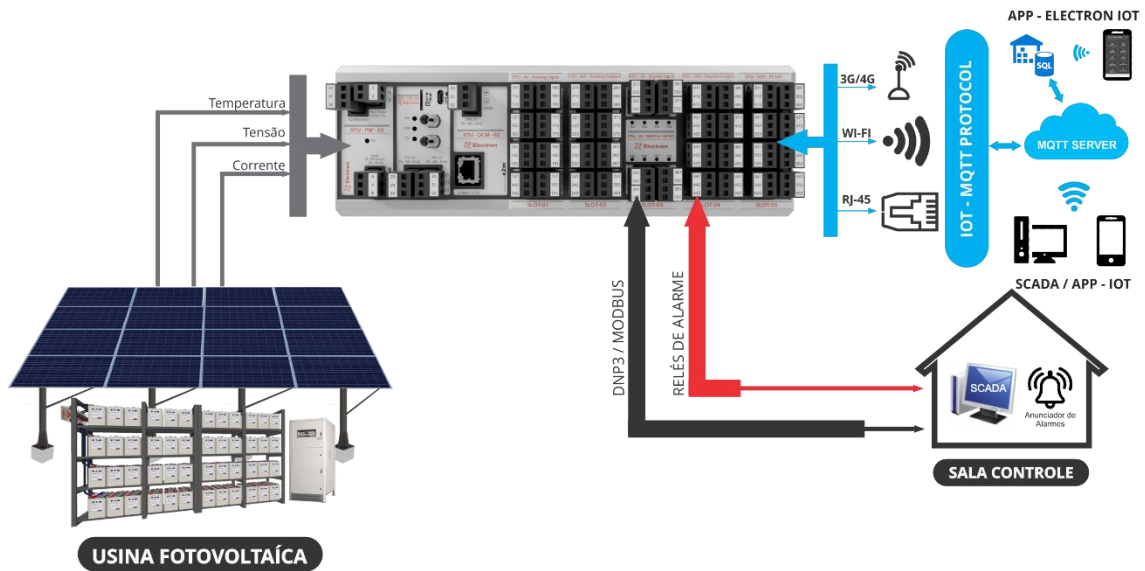

Figure 4 – Solar Power Plant

APPLICATION EXAMPLE – AUTOMOTIVE INDUSTRIES

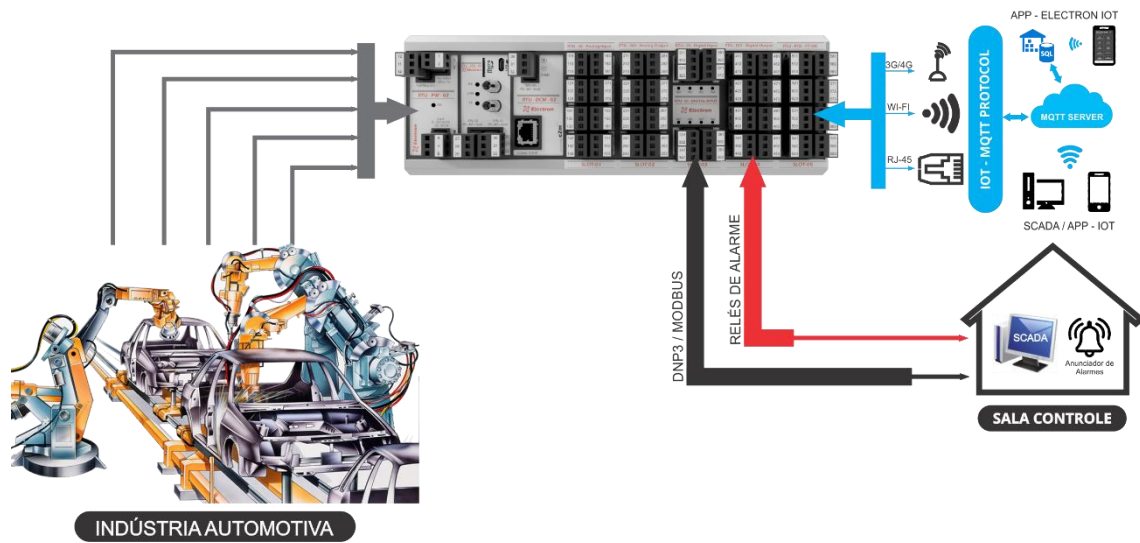

Figure 5 – Industry Sectors

APPLICATION EXAMPLE – AGRICULTURAL SECTOR

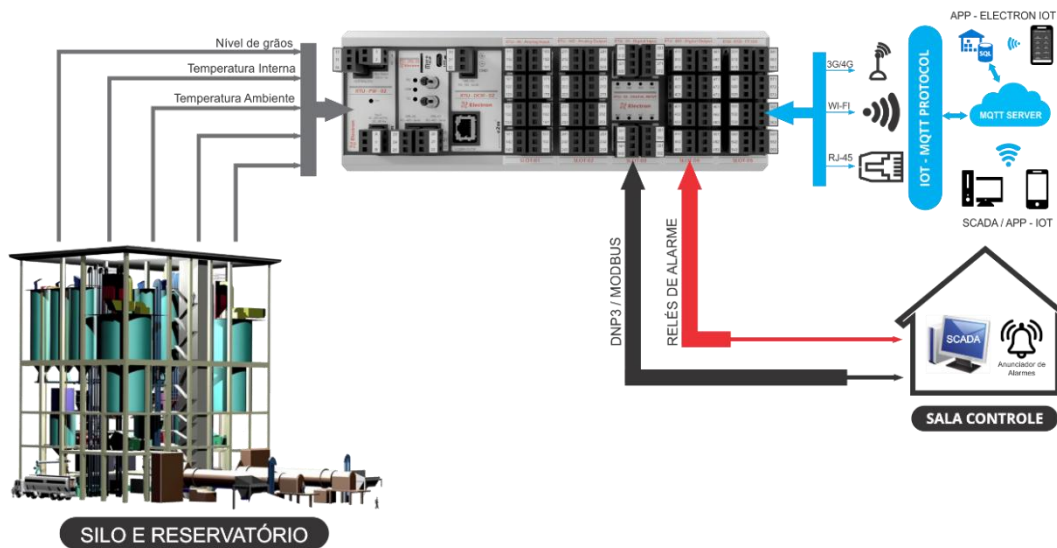

Figure 6 – Agricultural Sector

SIGNAL PROCESSING – MAIN AND AUXILIARY MODULES

The RTU is an equipment with a high capacity for processing input and output signals. There are many application possibilities, given the volume of data that this equipment can concentrate, monitor, supervise, process and operate. The tables below present the characteristics and description of each of these signs:

RTU – Core and Auxiliary Modules		
Abbreviation	Function	Description
PW	POWER SUPPLY	1 Universal power input with range of 85...265 Vdc/Vac. With a frequency range of 50/60 Hz.
	AUXILIARY POWER OUTLET	1 auxiliary output contact that offers 24 Vdc (stabilized) voltage, 83 mA current and 2 Watts of power and isolation of 2 KV / 60 Hz / 1 minute.
	FAILED RELAY (WATCHDOG)	1 relay output to indicate a failure to read any sensor. This relay is dedicated to alerting you that the RTU is not receiving a reliable signal on one of its inputs.
CPU	MULTIMODE FIBER INPUT	1 Input via ST connector for conversion of RS-485 signal (2 wires, metallic twisted pair) to optical fiber. Recommended for use in electric power substations, offshore platforms and environments with high levels of noise, induction and electromagnetic disturbances.
	RS-485 SERIAL (SLAVE)	Up to 2 RS-485 digital inputs (ANSI/TIA/EIA-485-A) with option to select Modbus RTU, Modbus TCP and DNP3 level 2 serial communication protocol, for remote access of all monitored parameters and variables.
	MICRO-USB INPUT	1 USB input for communication with the free use UseEasy™ Parameterization Software.
	MICRO SD CARD INPUT	1 Input for Class 10 Micro SD Card (10mB/s). Log writing is performed as a function of time and the variation of the measured quantity, and the variables that will be selected for writing are configurable.
	SFP INPUT	3 SFP (Small Form-factor Pluggable) interfaces, 2 for Ethernet (ETH1 and ETH2) in Bridge for 100base Transceiver standard and 1 Serial RS85. Traffic data in IEC61850.
DCM	WIRELESS INTERNET COMMUNICATION	Protocols: Modbus TCP – WIFI; Modbus RTU – WIFI and MQTT for IOT monitoring.
	RS-485 SERIAL (SLAVE OR DEDICATED MASTER)	1 RS-485 serial input (ANSI/TIA/EIA-485-A) with option to select Modbus RTU, Modbus TCP and DNP3 level 2 serial communication protocol, for remote acquisition of all monitored parameters and variables. IMPORTANT: For use of this master input, Electron do Brasil must be consulted and informed about the details of the desired application.
	SIM CARD SLOT	1 SIM Card Slot - NB IoT (4G/5G), for remote monitoring via IoT using SCADA systems based on MQTT protocol.
	RJ-45 INPUT	1 RJ-45 connector input for communication via Ethernet TCP/IP with Modbus TCP protocols; Modbus RTU and MQTT for remote access of all monitored parameters and variables.

Table 1 – Main and Auxiliary Modules.

SIGNAL PROCESSING – INPUT MODULES (INPUTS)

RTU – Input Modules		
Abbreviation	Function	Description
OUCH	ISOLATED ANALOG INPUT	8 Isolated Analog Inputs of 0...24 Vdc and 0...20 mA.
OF	ISOLATED DIGITAL INPUT	8 Isolated Digital Inputs 12...300 Vdc/Vca.
PNI	PNP AND NPN INPUT	8 Active PNP/NPN inputs 0...24Vdc/5mA per channel.
RTD	PT-100 RTD INPUT	8 PT-100 RTD resistive signal inputs (-50...850 °C).
DPT	DIGITAL INPUT / RTD INPUT PT-100	4 Isolated Digital Inputs 12...300 Vdc/Vac.
		4 PT-100 RTD resistive signal inputs (-50...850 °C).
APT	ANALOG INPUT/RTD INPUT PT-100	4 Isolated Analog Inputs 0...24 V DC and 0...20 mA,
		4 PT-100 RTD resistive signal inputs (-50...850 °C).
DPN	DIGITAL INPUT/PT-100 INPUT/INPUT LEVEL	4 Isolated Digital Inputs 12...300 Vdc/Vac.
		2 PT-100 RTD resistive signal inputs.
		2 Resistive inputs 0...400 Ohms.

Table 2 – Input modules of the RTU.

SIGNAL PROCESSING – OUTPUT MODULES

RTU – Output Modules		
Abbreviation	Function	Description
TO	ANALOG OUTPUT	8 Isolated Analog Outputs of 0...24 Vdc and 0...20 mA.
OF	DIGITAL OUTPUT	8 Outputs Digital Relay SPDT (NAF) with 6 A.

Table 3 – Output modules.

PROCESSAMENTO DE SINAIS – MODULOS DEDICADOS PARA TRAFOS (INPUTS/OUTPUTS)

RTU – Dedicated Transformer Modules (Inputs/Outputs)		
Abbreviation	Function	Description
RBM	MEMBRANE BAG RELAY	1 Liquid Sensor Input (SLE) dedicated to detecting bag rupture and/or transformer membrane, or leaks.
MTTP	TEMPERATURE MONITORING (ANSI 23, 26, 49/49I)	4 Inputs for reading resistive signal from RTD PT-100 type sensors.
		4 Inputs with 4...20 mA Split-Core CT range for current signal reading.
DVR	VOLTAGE REGULATOR (ANSI 90)	4 Inputs for reading voltage from 0 to 280 Vac (3 phases and neutral).
		3 Inputs for 0-10Aac Split-Core CT for reading phase current.
MNO	LEVEL MONITOR(ANSI 71/71C)	1 Resistive signal input (Magnetic float) with a range of 0...400 Ohms for oil level reading of the Transformer Conservator.
		1 Resistive signal input (Magnetic float) with a range of 0...400 Ohms for reading the oil level of the Transformer tank under load Switch.
OLTC-01	MOTOR TRANSDUCERLOAD CHANGER	1 Input for voltage reading up to 350 Vac (between phases) + 1 Input with 4...20 mA range of Split-Core CT for reading 1-phase AC current signal from the On-Load Changer Motor.
OLTC-02	MOTOR TRANSDUCERLOAD CHANGER	1 Input for voltage reading up to 350 Vdc (between phases) + 1 Input with internal Shunt type resistor for direct reading of AC current signal.

Table 4 – Dedicated modules (Inputs/Outputs) for transformers

SOURCE MODULE - PW

Each RTU-PW-00 and PW-01 **Power Supply module** occupy 01 SLOT space and the **RTU-PW-00** occupies 02 SLOT spaces, and only 01 module can be mounted on each Remote. Every RTU-PW module from Remota contains the following characteristics:

- The **Auxiliary Output** is commonly used to power analog transducers and sensors. Auxiliary Output is optional and must be added to this module during the generation of the order request code.
- The **Power Input** and the **Fault Relay** must be part of the RTU-PW module of Remota.

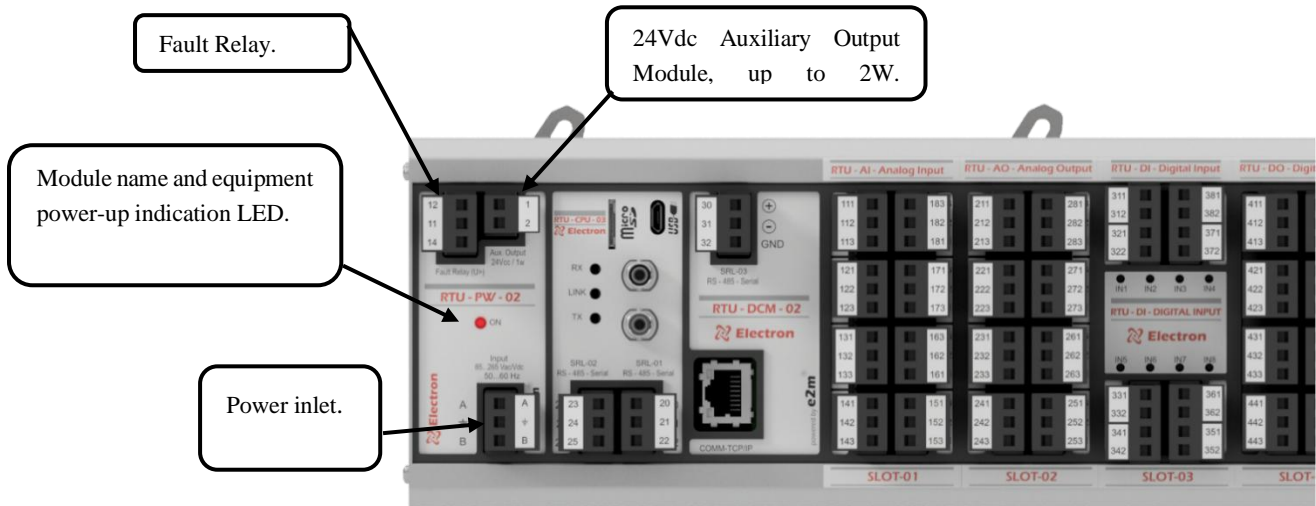

Technical Data of Input Power Supply

Operating Voltage Range	85 to 265 Vdc/Vac
Operating Frequency Range	50 to 60 Hz
Operating Temperature Range	-40 to 85 °C
Energy Consumption	15 W (PW-00 E PW-01) / 30 W (PW-02)

Technical Data of Auxiliary Output (Optional)

Output Voltage	24 Vdc – Stabilized
Max. drained current	83 mA
Max. power Provided	2 W
Galvanic Isolation	2 kV / 60Hz / 1 minute

Technical Data of Fault Relay

Contact Capacity / (Resistive Load)	125 VCA/15 A, 250 VCA/10 A, 24 VCC/15 A
Maximum switching current	6 Amps
Minimum switching current	500 mW/12 V/10 mA
Maximum Switching Power	1500 VA – 180 W
Maximum switching voltage	400 VAC / 125 VDC
Mechanical life	10 ⁶ operations minimum 300 cycles (operations/min);
NA uptime	8 ms (max)
Downtime	4 ms (max)
Dielectric strength between coil and contacts	4000 VAC (RMS)
Dielectric strength between open contacts	1000 VAC (RMS)
Initial insulation resistance	1000MΩ (500VDC)
Vibration resistance	10~55 Hz (dual amplitude 1.1 mm/6G)

Table 5 – Technical data of the source module.

SOURCE MODULE CONNECTION DIAGRAMS – PW

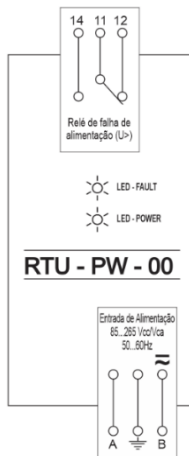

Figure 8 – PW-00 Power Module, without auxiliary output.

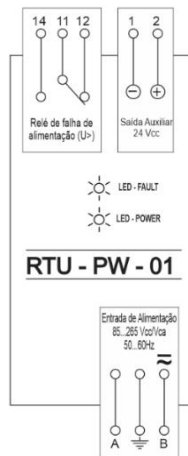

Figure 9 – PW-01 Power Module, with auxiliary output.

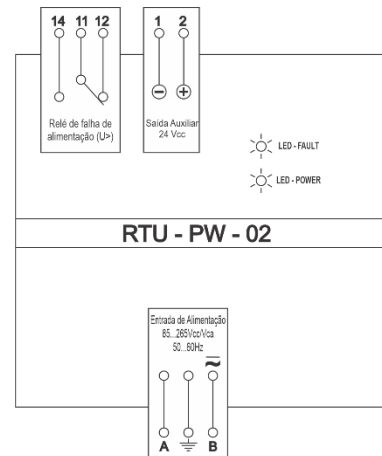

Figure 10 – PW-02 Power Module, with auxiliary output.

PROCESSING MODULE – CPU

- Each **RTU-CPU** module occupies 01 SLOT space, and only 01 module can be mounted on each Remote and can contain the following characteristics:
- **Micro-USB input** must integrate the RTU-CPU module from Remota for configuration via software.
- **USB-C input** from model 09 integrates Remota's RTU-CPU module for configuration via software.
- **Micro SD Card input** to record and store the monitored data on a Class 10 Micro SD Card (**10MB/s**), Variables can be selected for recording and log registration is performed as a function of time and measured quantity variation (optional).
- **RS-485 communication ports** (ANSI/TIA/EIA-485-A) with the possibility of configuring different **Slave** protocols on each output and configuring a **Master** port with **Modbus-RTU protocol**.
- **Multimode Fiber (ST) communication port** resistant to EMI / RFI and current fluctuations, ideal for data communications near Transformers, heavy electrical equipment and other electrical or radio interference.
- **SIM Card (NB IoT) slot** for access to IoT monitoring through Monitrafo.com, the card can be purchased directly from an NB IoT provider (vivo, claro, Tim) or consult us for pricing of the plans.
- **Internal modem with 3 Dbi antenna**, for connection to any WIFI network and traffic protocols (Modbus, DNP3 and IoT).
- **SFP (Small Form-factor Pluggable) communication interface** has the option of up to 3 SFP ports, 2 Ethernet in Bridge mode (ETH1 and ETH2) and 1 RS485 serial, for the use of these ports it is necessary to use **SFP transceiver base 100 Mb/s** with LC / SC and RJ45 type connectors.
- **Details Communication Protocol IEC61850:**
 - IEC 61850-8-1 (MMS)
 - IEC 61850-7-2
 - IEC 61850-7-3
 - IEC 61850-7-4 (LN)
 - ISO 9506
 - RFC 1006 (TPKT)
 - ISO 8073(COTP)

Input for Class 10 micro SD Card
(10MB/s).

Multimode Fiber Optic
Communication Input. (Optional)

Up to 2 Inputs for RS485 Serial
Communication (ANSI/TIA/EIA-

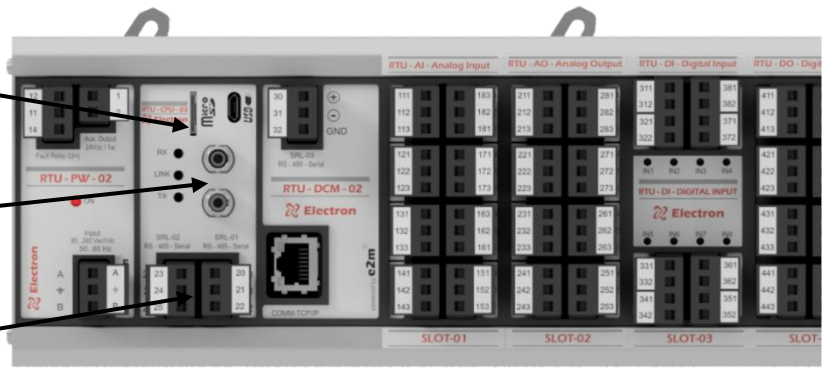
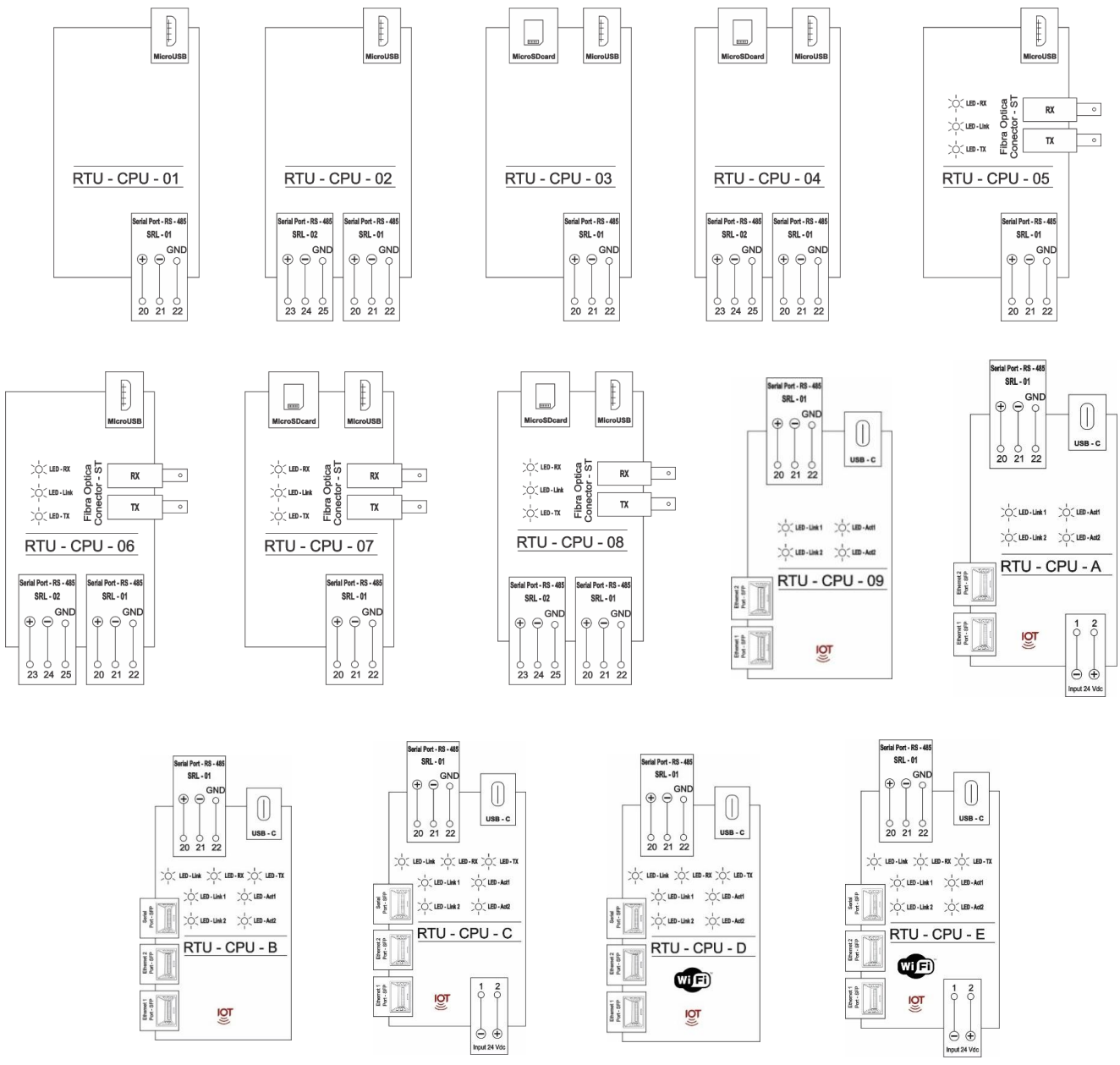

Figure 11 - CPU Module Illustration

PROCESSING MODULE – CPU CONNECTION DIAGRAMS





Figura 12 – Módulos CPU

Technical Data of RS-485 Serial Communication Module	
Transmission Mode	Half-Duplex (two-wire)
Maximum length of communication cables	1200 meters
Communication Speed	Auto Baud Rate 2,400 to 57,600 bps (Automatically detects the speed of the communication network)
Maximum number of devices on the network	32 units
Isolation	2 kV / 60Hz / 1 minute

Technical Data of Communication Module with (Optical Fiber)	
Maximum fiber length	3000 m (multimode optical fiber, 62.5/125 μm)
Fiber Connector	ST Standard
Minimum transmit power	-14.0 dB.m (multimode optical fiber, 62.5/125 μm)
Maximum transmit power	-10.0 dB.m (multimode optical fiber, 62.5/125 μm)
Minimal receive sensitivity	-24 dB.m (multimode optical fiber, 62.5/125 μm)
Multimode Fiber Optic Compatible	50/125 μm, 62.5/125 μm, 100/140 μm and 200 μm
Wavelength	850 days

Technical Data of TCP/IP Communication Module via RJ-45	
Return Loss	-18dB minimum @ 1-30MHz-16dB minimum @ 30-60MHz-12dB minimum @ 60-90MHz
Common Mode Bounce Rate	-30dB Minimum @ 1-100MHz
Isolation	2 kV / 60Hz / 1 minute

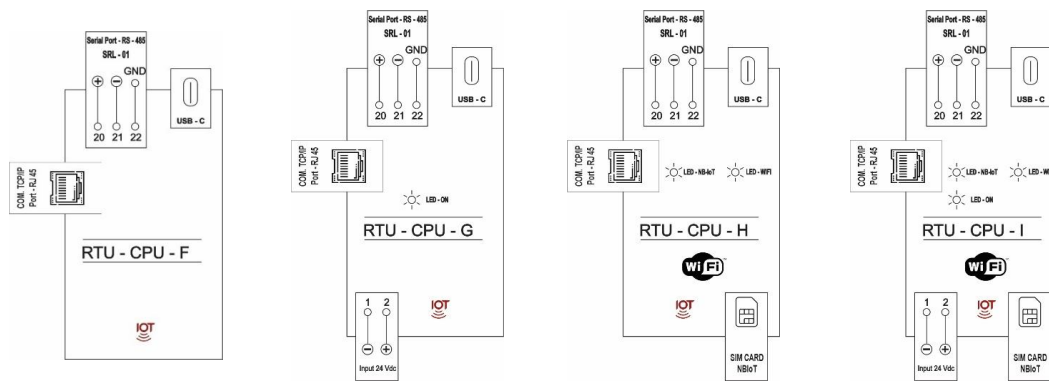
Technical Data of WIFI Module	
Standards	802.11 b/g/n/e/i
Safety Protocols	WPA/WPA2/WPA-Enterprise
Data Rate	Up to 150 Mbps
Transmit Power	Up to 21 dBm
Frame Encapsulation	802.11h/RFC 1042
Automatic Beacon	Monitoring/Scanning

Table 6 – Technical data communication module

SFP COMMUNICATION INTERFACE

Small Form-factor Pluggable (SFP) port standards refer to the physical interfaces used to connect optical or electrical transceivers in network equipment such as switches, routers, and servers. There are several versions and standards of SFP ports, as technology evolves.

Within the **SFP (Small Form-factor Pluggable) standard**, there are several transceiver models available, each suitable for different cable types, distances, and applications (optical or electrical). Here are the SFP transceiver models supported by RTU

In the specific case of the RJ45 SFP, the interface uses twisted-pair Ethernet cable, allowing communication in local networks, in which the supported communication protocols are IEC 61850 and Modbus TCP/IP, enabling the integration of the RTU with automation, supervision and protection systems in industrial and substation environments.

Technical Data of RS-485 Serial Communication Module			
Model / Interface	Distance	Working Temperature	Connector Type
Transceiver SFP - BIDI - 155M ~ 1.25G	20 ~150 Km	-40 + 85°C	LC/SC (Single)
SFP Transceiver - DUAL - 155M ~ 1.25G	2~150 Km	-40 + 85°C	LC (Double)
Transceiver SFP - 10/100/1000Mbps - Cobre - RJ45	30 meters	-40 + 85°C	RJ-45

Table 7 – CPU Technical Data

DATA COMMUNICATION MODULE - DCM

Each Communication module is optional and RTU-DCM occupies 01 SLOT space, and only 01 module can be mounted on each Remote. Remota's RTU-DCM Module contains the following features:

- WIFI (Modbus TCP and RTU/DNP3/MQTT);
- Bluetooth for parameterization via Mobile APP and Virtual HMI;
- Input for TCP/IP Communication (Modbus TCP and RTU/DNP3/MQTT);
- RS-485 Serial Input (Slave or Dedicated Master);
- SIM Card (NB IoT) slot for access to IoT monitoring;

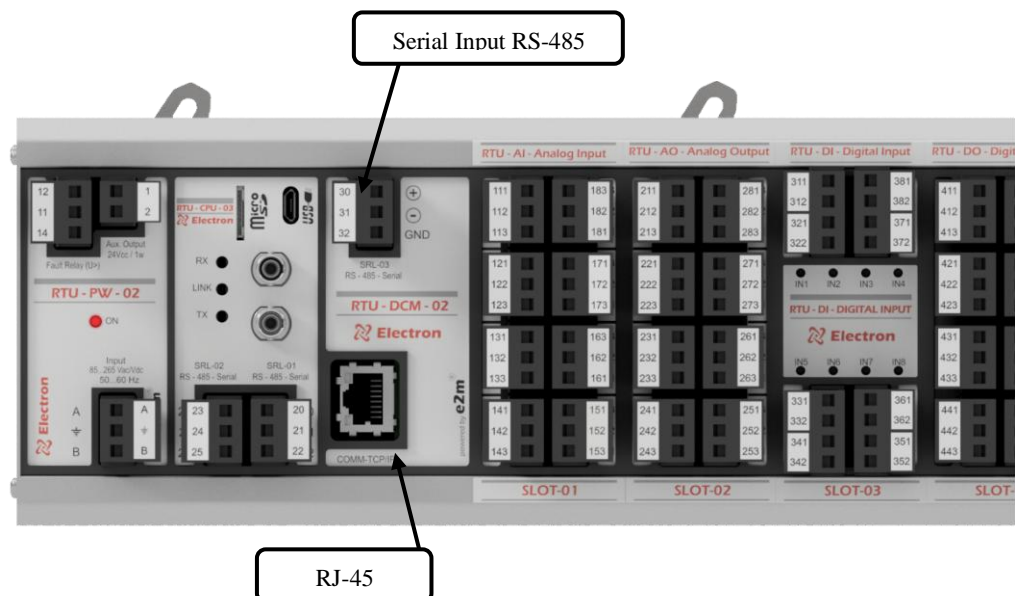

Figure 13 - Illustration of the Communication Module

PROCESSING MODULE CONNECTION DIAGRAMS – DCM

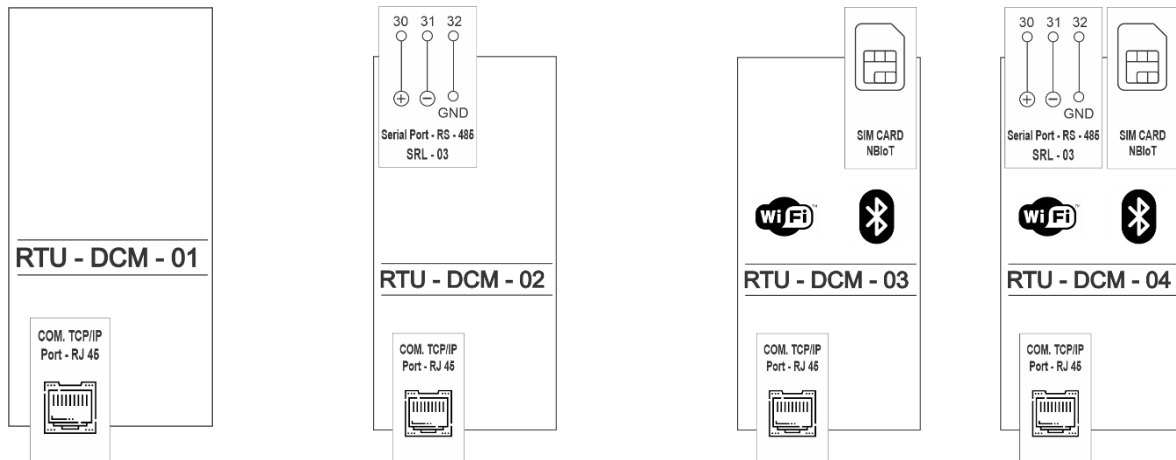

Figure 14 - Communication Module Diagram

Configuration of Communication Protocols and Ports									
Model	Modbus RTU	Modbus TCP/IP	DNP3	MQTT	SERIAL RS485	RJ45 PORT	SIM CARD NBioT	WIFI	BLUETOOTH
DCM-01	✓	✓	✓			✓			
DCM-02	✓	✓	✓		✓	✓			
DCM-03	✓	✓	✓	✓		✓	✓	✓	✓
DCM-04	✓	✓	✓	✓	✓	✓	✓	✓	✓

Table 7 – DCM Configuration Table

Technical Data of Bluetooth BLE Module	
Version	4.2
Frequency	2402 MHz to 2480 MHz

Technical Data of TCP/IP Communication Module via RJ-45	
Return Loss	-18dB minimum @ 1-30MHz-16dB minimum @ 30-60MHz-12dB minimum @ 60-90MHz
Common Mode Bounce Rate	-30dB Minimum @ 1-100MHz
Isolation	2 kV / 60Hz / 1 minute

Technical Data of WIFI Module	
Standards	802.11 b/g/n/e/i
Safety Protocols	WPA/WPA2/WPA-Enterprise
Data Rate	Up to 150 Mbps
Transmit Power	Up to 21 dBm
Frame Encapsulation	802.11h/RFC 1042
Automatic Beacon	Monitoring/Scanning

Table 8 - Technical Data of the Communication Module

ANALOG INPUT MODULE - AI

Each Analog Input Module reads direct voltage (Vdc) and direct current (mA) signals, and occupies 01 SLOT space of the Remote, and up to **8 modules** can be mounted on each equipment that corresponds to **64 inputs**;

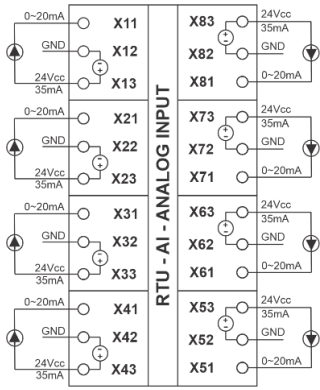

Letra X = nº SLOT de instalação do módulo

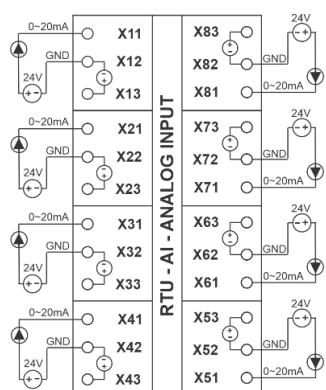

Letra X = nº SLOT de instalação do módulo

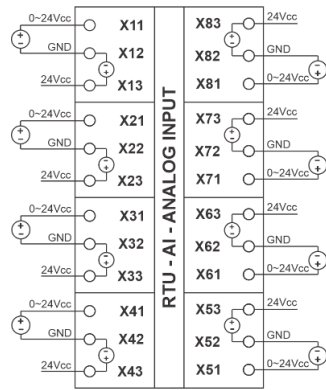

Letra X = nº SLOT de instalação do módulo

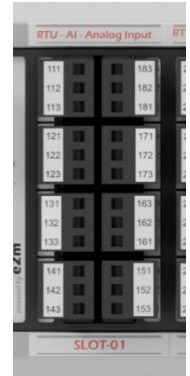

Figure 15 – Schematic – AI – 0-20mA

Figure 16 – Schematic - AI 0-20mA - with External Source

Figure 17 – Schematic – AI – 0-24Vdc

Figure 18 - Illustration

Technical Data of Analog Input Module	
Auxiliary Voltage of the module	24 Vdc and 35mA (max) per input
Resolution	16-bit
Maximum Analog Input Error	0.1% end of scale
Current reading range	0 to 20 mA;
Direct voltage reading range	0 to 24 Vdc
Isolation	2 kV / 60Hz / 1 minute

Table 9 – Technical Data of the Direct Voltage and Current Input Module

RELAY DIGITAL OUTPUT MODULE – DO

Each NAF Digital Output input module occupies 01 SLOT space of the Remote, and up to 8 modules can be mounted on each equipment that corresponds to 64 inputs;

To use **more than 2** digital output modules (relays) the **PW-02** power supply is required.

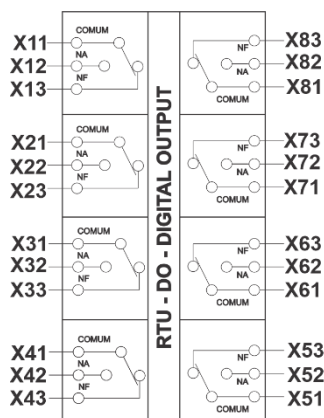

Letra X = nº SLOT de instalação do módulo

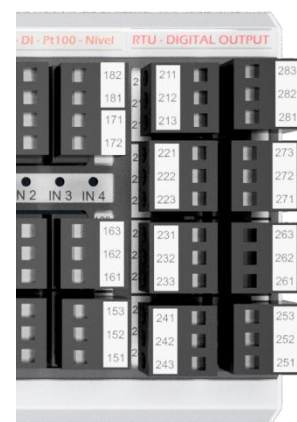

Figure 19 – Diagram of connecting digital outputs to SPDT NAF Relay

Figure 20 - Illustration of the module digital outputs to SPDT NAF Relay

Technical Data of NAF Digital Output Module	
Contact Capacity / (Resistive Load)	125 VCA/15 A, 250 VCA/10 A, 24 VCC/15 A
Maximum switching current	6 Amps
Minimum switching current	500mW/12V/10mA
Maximum Switching Power	1500VA – 180W
Maximum switching voltage	400 VAC / 125VDC
Mechanical life	10 ⁶ operations minimum 300 cycles (operations/min);
NA uptime	8ms (max.)
Downtime	4ms (max.)
Dielectric strength between coil and contacts	4000 VAC (RMS)
Dielectric strength between open contacts	1000 VAC (RMS)
Initial insulation resistance	1000MΩ (500VDC)
Vibration resistance	10~55Hz (dual amplitude 1, 1mm/6G)

Table 10 – Technical Data of the NAF Digital Relay Output Module

ANALOG OUTPUT MODULE - AO

Each Analog Output Module occupies 01 SLOT space, and up to 8 modules can be mounted on each REMOTE that corresponds to **64 inputs**;

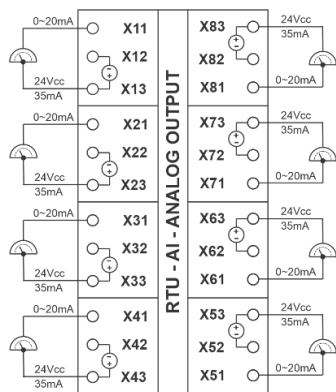

Letra X = nº SLOT de instalação do módulo

Figure 21 - Output Diagram - Active

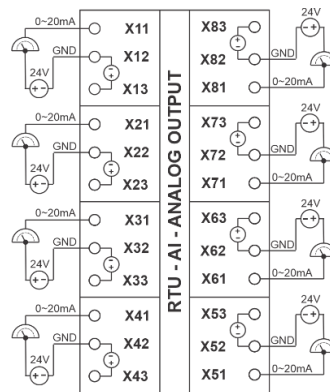

Letra X = nº SLOT de instalação do módulo

Figure 22 - Output Diagram - Passive

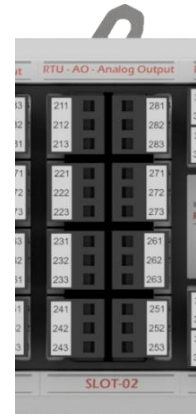

Figure 23 - Analog Output Illustration

Technical Data of Analog Output Module	
Auxiliary Voltage of the module	24 Vdc and 35mA (max) per input
Resolution	12-bit
Maximum Analog Output Error	0.1% end of scale
Current Output	0 - 20 mA
Maximum Load for the selected range	0 - 1mA = 20 KΩ
	0 - 5mA = 4 KΩ
	0 - 10mA = 2 KΩ
	0 - 20mA = 1 KΩ
	4 - 20mA = 1 KΩ
Isolation	2 kV / 60Hz / 1 minute

Table 11 - Analog Output Module Technical Data

TEMPERATURE READING MODULE – RTD – PT100

Each RTD input module has 8 inputs for PT-100 and occupies 01 SLOT space, and up to 8 modules can be mounted on each REMOTE that corresponds to **64 inputs**;

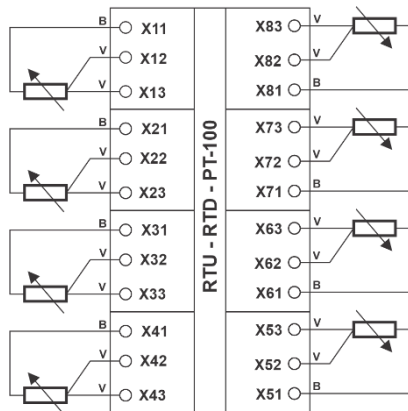

Letra X = nº SLOT de instalação do módulo

Figure 24 - PT100 RTD Connection Diagram

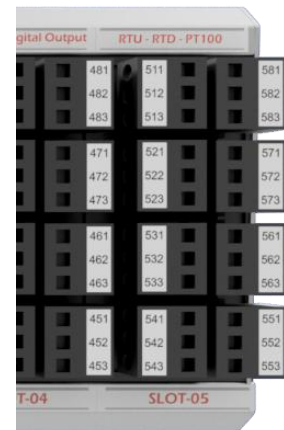

Figure 25 - Module Illustration - RTD PT100

Technical Data of PT100 RTD Temperature Sensor Input	
Resolution	15-bit
Temperature Reading Range	-50 to 850°C
Nominal temperature resolution	0.031°C
Fault detection	Open RTD and Short RTD
Cable resistance	0 to 30 Ω
Isolation	2 kV / 60Hz / 1 minute

Table 12 – Technical Data of PT100 RTD Temperature Sensor Input

DIGITAL INPUT MODULE - DI

Each Digital Input module occupies 01 SLOT space of the Remote, and up to **8 modules** can be mounted on each equipment that corresponds to **64 inputs**;

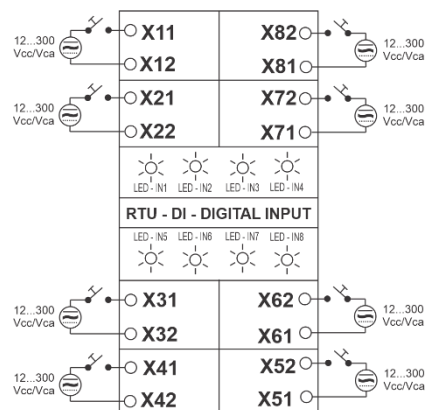

Letra X = nº SLOT de instalação do módulo

Figure 26 – Digital Input (DI) Connection Diagram

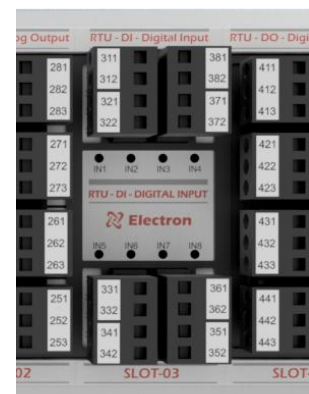

Figure 27 - Digital Input (DI) Illustration

Digital Entry (DI) Technical Data	
Ticket Type	Sink / Source
Inputs and Sensitivity Range	8 Isolated Digital Inputs 12...300 Vdc/Vca.
Construction Characteristics	Independent and Galvanically Isolated
Minimum time to pulse detection	500 mS
Response Time	500 mS
Frequency Range for Pulse Counting	100 Hz ~ 10 KHz
Galvanic Isolation	2KV/60Hz/1 minute

Table 13 – Table of technical data for digital input

MÓDULO DE ENTRADA DIGITAL / ENTRADA PT-100 / LEITURA DE NÍVEL - DPN

Cada Módulo ocupa 01 espaço de SLOT, podendo ser montados até 8 módulos em cada REMOTA que corresponde a 64 entradas;

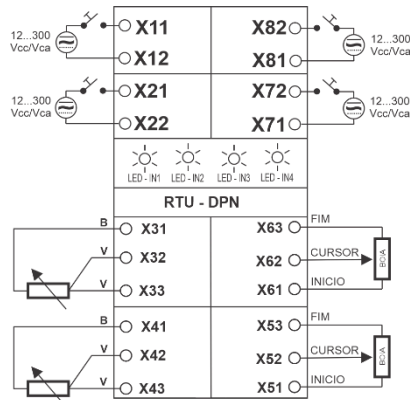

Letra X = nº SLOT de instalação do módulo

Figure 28 – Connection Diagram - DPN

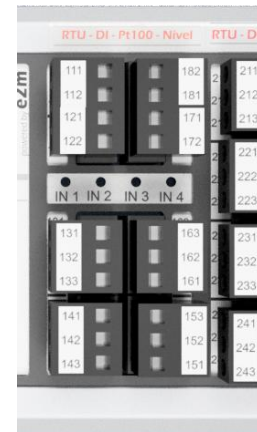

Figure 29 – Module Illustration - DPN

Technical Data Input Module for PT100 RTD Temperature Sensor	
Resolution	15 bits
Nominal temperature resolution	0,031°C
Fault detection	RTD aberto e RTD em curto
Cable resistance	0 a 30 Ω
Isolation	2 kV / 60Hz / 1 minuto

Technical Data Oil Level Module	
Resistive Input Signal Reading Range	0 a 400 ohms (Magnetic buoy)
Level measurement range	0 a 100%

Table 14 – Technical data of the RTU module – DPN – Digital Input – PT100 – Level.

DEDICATED RBM MODULE – MEMBRANE BAG RELAY

The RTU-RBM Module occupies 01 SLOT space and has a 3-wire input for Liquid Detection Sensor (SLE), two Relays for Alarm activation for infiltration of insulating oil inside the bag and an alarm to indicate failure in the liquid sensor.

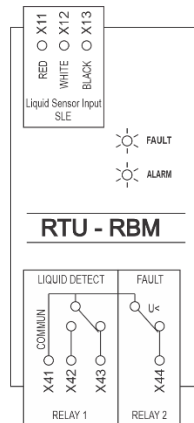

Letra X = nº SLOT de instalação do módulo
Figure 30 – Connection Diagram - RBM

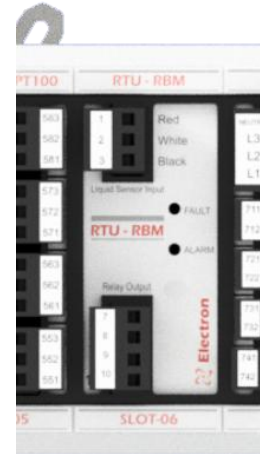

Figure 31 – Module Illustration - RBM

RTU-RBMI Technical Data	
Sensor Input	SLE
Switching Operating Temperature	-40 to +85°C
Maximum Switching Capacity	70W/250VA
Maximum Driving Current	6 Amps
Outbound Contact	1NAF and 1NF

Technical Data – SLE	
Sensor Type	Photo: Transistor
Dimension	∅ 14x70mm / M16x70mm
Material	AISI-304 Stainless Steel
Sensor Operating Temperature	50 µS
Degree of Protection	IP67
Response Time	0 to 5 bar
Cape	3 x 18 AWG with grounding mesh

Technical Data – CPC	
Material	Injected aluminum
Recommended Torque	46 Nm
Degree of Protection	IP65
Connection Head	4 wires

Table 15 – Table of technical data of RBMI, SLE and CPC.

GENERAL TECHNICAL DATA

REMOTE - RTU	
Operating Voltage Range	85 and 265 Vcc / Vca 50/60 Hz
Operating Temperature Range	-40°C to +85°C
Energy Consumption	< 15 W
Maximum number of entries	64
Dimensions Box (DIN Standard) IEC 61554	As shown in Table 17 (Dimensions)
Hardware Packaging	Aluminium
Fixation	DIN standard for 35mm rail
Protection	IP40 (Front), IP 20 (Connectors)

Table 16 – General RTU technical data

TYPE TRIALS MET

- Applied Voltage (**IEC 60255-5**): 2kV / 60Hz / 1 min. (against land);
- Voltage Impulse (**IEC 60255-5**): 1.2/50 µsec. / 5kV / 3 neg. and 3 sec. / 5 sec. Interval;
- Electrostatic Discharges (**IEC 60255-22-2**): Air mode = 8kV / Counted mode = 6 kV;
- Immunity to radiated electromagnetic disturbance (**IEC61000-4-3**): 80 to 1000 MHz / 10V/m;
- Immunity to Fast Electrical Transients (**IEC60255-22-4**): Alim/Input/Outputs=4Kv/common 2Kv;
- Surge Immunity (**IEC60255-22-5**): phase/neutral 1Kv, 5 per polar (±) - phase-to-ground/neutral-to-ground 2Kv, 5 per polar
- Immunity to conducted electromagnetic disturbances (**IEC61000-4-6**): 0.15 to 80 MHz / 10V/m;
- Climate Test (**IEC60068-21-14**): - 40°C + 85°C / 72 hours;
- Vibration Resistance (**IEC60255-21-1**): 3 axes / 10 to 150Hz / 2G / 160min/axis;
- Vibration Response (**IEC60255-21-1**): 3-axis / 0.075mm-10 at 58 Hz / 1G from 58 to 150 Hz / 8min/axis;

DIMENSIONS



Figure 32 – Front View of the Remote

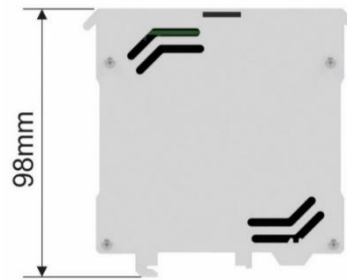

Figure 33 – Left Side View of the Remote

SIZING TABLE								
CORE MODULES	1 SLOT	2 SLOTS	3 SLOTS	4 SLOTS	5 SLOTS	6 SLOTS	7 SLOTS	8 SLOTS
PW-00/PW-01 + CPU	114,5 mm	152,0 mm	189,5 mm	227,0 mm	264,5 mm	302,0 mm	339,5 mm	377,0 mm
PW-00/PW-01 + CPU + DCM	152,0 mm	189,5 mm	227,0 mm	264,5 mm	302,0 mm	339,5 mm	377,0 mm	414,5 mm
PW-02 + CPU	152,0 mm	189,5 mm	227,0 mm	264,5 mm	302,0 mm	339,5 mm	377,0 mm	414,5 mm
PW-02 + CPU + DCM	-----	-----	264,5 mm	302,0 mm	339,5 mm	377,0 mm	414,5 mm	452,0 mm

As per Table 17 - Dimensions

SENSORS FOR APPLICATION WITH RTU

*Figure 34 – PT-100 RTD Temperature Sensor
with head for level adjustment*



*Figure 35 – PT-100 RTD Temperature Sensor
No head and gland for level adjustment*



Figure 36 – PT-100 Flexible Temperature Sensor



*Figure 37 – Magnetic level
indication float.*



Figure 38 – Pressure sensor



Figure 39 – 4...20mA Split core/Clamp CT



*Figure 40 – Inductive and capacitive sensors
PNP or NPN*



*Figura 41 – Sensor de
Ruptura de Disco*



*Figure 42 – SLE Liquid Detection
Sensor.*

ATTACHMENT INSTRUCTIONS

The Remote was developed to be fixed on DIN rail 35mm, follow the illustrated instructions below correctly to use it in your application:



Step One – Make sure the latches are not obstructing the DIN rail docking location

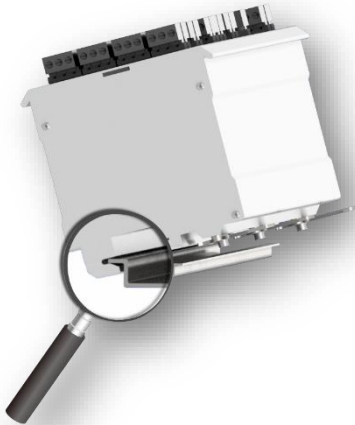

Second Step – Allocate this end of the DIN rail on one of the bases of the Remote as illustrated in the figure above.

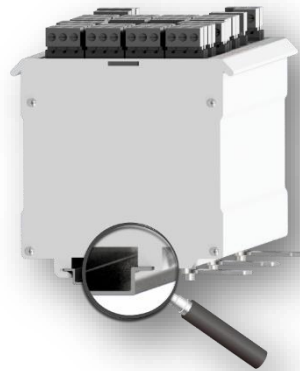

Terceiro Passo – Aloque a outra extremidade do trilho DIN na base da Remota, conforme ilustra a figura acima.

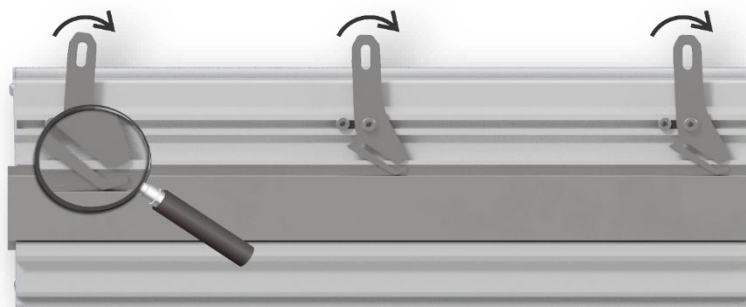

Step Four – With the base of the Remote properly allocated to the DIN rail, rotate the locks clockwise so that they are all properly fixed as illustrated in the figure above.

ORDER SPECIFICATION

Table 1 – Power Supply

Code	Description
N	No internal power supply (for this option you must use a CPU with 24 Vdc external power supply input)
0	30W Power Supply without auxiliary power output.
1	30W Power Supply with 24 Vdc (2 Watts) auxiliary power output.
2	60W Power Supply with 24 Vdc auxiliary power output (2 Watts).

Table 2 – Processing Module - CPU



Code	Description
1	1 RS-485 serial output (slave).
2	2 RS-485 (Slave) Serial Outputs.
3	1 RS-485 Serial Output (Slave) + 1 SD Card Input (datalogger).
4	2 RS-485 Serial Outputs (Slave) + 1 SD Card Input (datalogger).
5	1 Serial Output RS-485 (Slave) + Output with ST Fiber Optic connector.
6	2 Serial Outputs RS-485 (Slave) + Output with ST Fiber Optic connector.
7	1 RS-485 Output (Slave) + Output with ST Fiber Optic connector + 1 SD Card Input (datalogger).
8	2 RS-485 Outputs (Slave) + Output with ST Fiber Optic connector + 1 SD Card input (datalogger).
9	2 Portas SFP (ETH - bridge) + 1 Porta RS-485 (Master/Slave) + Conexão IoT (Monitrafo.com).
The	2 SFP Ports (ETH - bridge) + 1 RS-485 Port (Master/Slave) + IoT Connection (Monitrafo.com) + Input for external 24 Vdc / 30Watts power supply. (No power supply module required in the RTU).
B	2 Portas SFP (ETH - bridge) + 1 Porta SFP (RS485/serial) + 1 Porta RS-485 (Master/Slave) + Conexão IoT (Monitrafo.com).
C	2 SFP Ports (ETH - bridge) + 1 SFP Port (RS485/serial) + 1 RS-485 Port (Master/Slave) + IoT Connection (Monitrafo.com) + Input for external 24 Vdc / 30Watt power supply. (No power supply module required in the RTU).
D	2 Portas SFP (ETH - bridge) + 1 Porta SFP (RS485/serial) + 1 Porta RS-485 (Master/Slave) + Conexão IoT (Monitrafo.com) + Modem WiFi 3Dbi.
And	2 SFP Ports (ETH - bridge) + 1 SFP Port (RS485/serial) + 1 RS-485 Port (Master/Slave) + IoT Connection (Monitrafo.com) + 3Dbi WiFi Modem + Input for 24 Vdc / 30Watts external source. (No power supply module required in the RTU).
F	1 TCP/IP port with RJ-45 connector + 1 RS-485 port (Master/Slave) + IoT connection (Monitrafo.com).
G	1 TCP/IP port with RJ-45 connector + 1 RS-485 port (Master/Slave) + IoT connection (Monitrafo.com) + Input for external 24 Vdc / 30Watt power supply. (No power supply module required in the RTU).
H	1 TCP/IP port with RJ-45 connector + 1 RS-485 port (Master/Slave) + IoT connection (Monitrafo.com) + SIMCARD input for NBIoT connection.
I	1 TCP/IP port with RJ-45 connector + 1 RS-485 port (Master/Slave) + IoT connection (Monitrafo.com) + SIMCARD input for NBIoT connection + Input for external 24 Vdc / 30Watt power supply. (No power supply module required in the RTU).
J	2 SFP Ports (ETH – bridge) IEC61850 Communication Protocol + 1 RS-485 Port (Master/Slave) + IoT Connection (Monitrafo.com)

Table 3 – Communication Module - DCM



Code	Description
0	No communication module.
1	1 TCP/IP port with RJ-45 connector.
2	1 RS-485 Serial Output (Slave) + 1 TCP/IP Port with RJ-45 connector.
3	1 TCP/IP port with RJ-45 connector + 1 SIM Card slot + 3Dbi WiFi modem.
4	1 RS-485 Serial Output (Slave) + 1 TCP/IP Port with RJ-45 connector + 1 SIM card input + 3Dbi WiFi Modem.

Table 4 – Input and Output Modules

Code	Acronym	Function	Description
0	-	No Module	OPTION AVAILABLE ONLY FROM SLOT 2
2	OUCB	Isolated Analog Input	8 Isolated Analog Inputs of 0...24 Vdc and 0...20 mA.
3	DI	Isolated Digital Input	8 Isolated Digital Inputs 12...300 Vdc/Vca.
4	TO	Analog Output	8 Isolated Analog Outputs of 0...24 Vdc and 0...20 mA.
5	PNI	PNP and NPN Input	8 Active PNP/NPN inputs 0...24Vdc/5mA per channel.
6	OF	Digital Output	8 Outputs Digital Relay SPDT (NAF) with 6 A.
7	RTD	PT-100 RTD Input	8 Resistive signal inputs for reading PT-100 sensors (-50...850 °C).
8	DPT	Digital Input / RTD Input PT-100	4 Isolated Digital Inputs 12...300Vdc/Vac + 4 Resistive Signal Inputs PT-100 (-50...850 °C).
9	APT	Analog Input / RTD Input PT-100	4 Isolated Analog Inputs of 0...24 Vdc and 0...20 mA, 4 Resistive Signal Inputs PT-100 (-50...850 °C).
A	DPNI	Digital Input / PT-100 Input / Level Reading	4 Isolated Digital Inputs 12...300 Vdc/Vca + 2 PT-100 resistive signal inputs + 2 Resistive inputs 0...400 Ohms for level reading.
B	RBM	RBM Module – Bag Rupture Detector	1 Liquid sensor input (SLE) + 1 digital output to 6 A NAF relay + 1 Digital output to 6 A NF relay for indication of sensor failures.

SFP TRANSCEIVER ORDER SPECIFICATION
TRANSCEIVER SFP – BIDI – 155M – TEMP. TRABALHO -40 ~85°C



DISTANCE	FIBER TYPE	SIGNAL STRENGTH	SENSITIVITY	INTERFACE	CONNECTOR	WAVELENGTH	PART NUMBER ELECTRON	COD. ELECTRON
10Km	Monomodo	-15~-7 dBm	-34 dBm	Simple Bi-Directional	LC	1310 nm	ELT-PB3503-L10TD	PA1171A
						1550 nm	ELT-PB5303-L10TD	PA1171B
					SC	1310 nm	ELT-PB3503-S10TD	PA1170A
						1550 nm	ELT-PB5303-S10TD	PA1170B
20Km	Monomodo	-15~-7 dBm	-34 dBm	Simple Bi-Directional	LC	1310 nm	ELT-PB3503-L20TD	PA1172A
						1550 nm	ELT-PB5303-L20TD	PA1172B
					SC	1310 nm	ELT-PB3503-S20TD	PA1173A
						1550 nm	ELT-PB5303-S20TD	PA1173B
40Km	Monomodo	-9~-3 dBm	-34 dBm	Simple Bi-Directional	LC	1310 nm	ELT-PB3503-L40TD	PA1174A
						1550 nm	ELT-PB5303-L40TD	PA1174B
					SC	1310 nm	ELT-PB3503-S40TD	PA1175A
						1550 nm	ELT-PB5303-S40TD	PA1175B
60Km	Monomodo	-3~0 dBm	-34 dBm	Simple Bi-Directional	LC	1310 nm	ELT-PB3503-L60TD	PA1176A
						1550 nm	ELT-PB5303-L60TD	PA1176B
					SC	1310 nm	ELT-PB3503-S60TD	PA1177A
						1550 nm	ELT-PB5303-S60TD	PA1177B
80Km	Monomodo	-6~-3 dBm	-34 dBm	Simple Bi-Directional	LC	1310 nm	ELT-PB3503-L80TD	PA1178A
						1550 nm	ELT-PB5303-L80TD	PA1178B
					SC	1310 nm	ELT-PB3503-S80TD	PA1179A
						1550 nm	ELT-PB5303-S80TD	PA1179B
100Km	Monomodo	-3~0 dBm	-34 dBm	Simple Bi-Directional	LC	1310 nm	ELT-PB3503-L100TD	PA1180A
						1550 nm	ELT-PB5303-L100TD	PA1180B
					SC	1310 nm	ELT-PB3503-S100TD	PA1181A
						1550 nm	ELT-PB5303-S100TD	PA1181B
120Km	Monomodo	0~2 dBm	-36 dBm	Simple Bi-Directional	LC	1310 nm	ELT-PB3503-L120TD	PA1182A
						1550 nm	ELT-PB5303-L120TD	PA1182B
					SC	1310 nm	ELT-PB3503-S120TD	PA1183A
						1550 nm	ELT-PB5303-S120TD	PA1183B
150Km	Monomodo	-2~5dBm	-36 dBm	Simple Bi-Directional	LC	1310 nm	ELT-PB3503-L150TD	PA1184A
						1550 nm	ELT-PB5303-L150TD	PA1184B
					SC	1310 nm	ELT-PB3503-S150TD	PA1185A
						1550 nm	ELT-PB5303-S150TD	PA1185B

TRANSCEIVER SFP – 155M – TEMP TRABALHO -40 ~85°C



DISTANCE	FIBER TYPE	SIGNAL STRENGTH	SENSITIVITY	INTERFACE	CONECTOR	WAVELENGTH	PART NUMBER. ELECTRON	CÓD. ELECTRON
2Km	Monomodo	-15~-7 dBm	-34 dBm	Duplo	LC	1310 nm	ELT-P1303-02TD	PA1186
20Km	Monomodo	-9~-7 dBm	-34 dBm	Duplo	LC	1310 nm	ELT-P1303-20TD	PA1187
40Km	Monomodo	-9~-3 dBm	-34 dBm	Duplo	LC	1550 nm	ELT-P5503-40TD	PA1188
60Km	Monomodo	-3~-0 dBm	-34 dBm	Duplo	LC	1550 nm	ELT-P5503-60TD	PA1189
80Km	Monomodo	0~-2 dBm	-34 dBm	Duplo	LC	1550 nm	ELT-P5503-80TD	PA1190
100Km	Monomodo	-3~0 dBm	-34 dBm	Duplo	LC	1550 nm	ELT-P5503-100TD	PA1191
120Km	Monomodo	-2~1 dBm	-36 dBm	Duplo	LC	1550 nm	ELT-P5503-120TD	PA1192
150Km	Monomodo	1~5 dBm	-36 dBm	Duplo	LC	1550 nm	ELT-P5503-150TD	PA1193

TRANSCEIVER SFP – 10/100/1000Mbps – Cobre – RJ45 – TEMP. TRABALHO -40 ~85°C

DISTANCE	CONECTOR	PART NUMBER ELECTRON	CÓDIGO ELECTRON
100 Metros	RJ45	ELT-PTT2-RS1	PA1169

TYPES OF SFP TRANSCEIVER CONNECTIONS

Figure 43 – 1 Bidirectional Optical Fiber + RJ45
 PA1169+PA1170B



Figure 44 – 2 RJ45
 2 PA1169

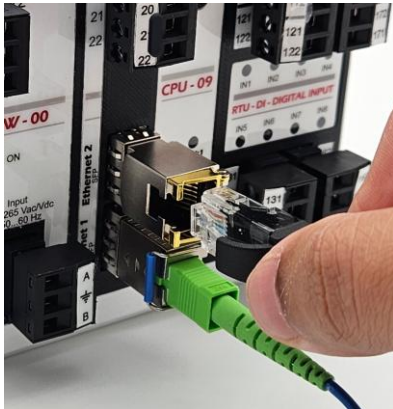

Figure 45 – 2 Double Optical Fiber
 2 PA1187

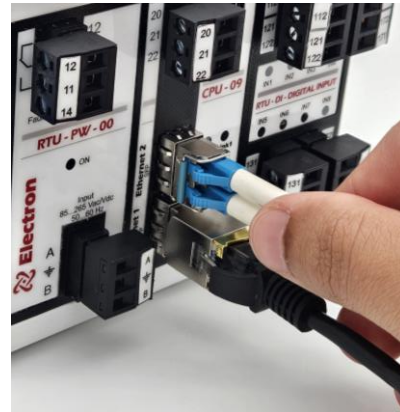

Figure 46 – 1 Dual Optical Fiber + RJ-45
 PA1187 + PA1169



Figure 47 – 1 Double Optical Fiber + 1 Bidirectional Optical Fiber
 PA1187+PA1170B

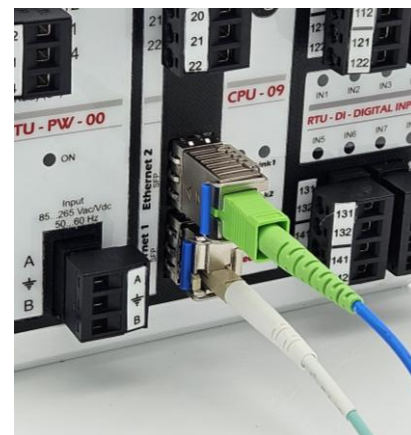

Figure 48 – 1 Bidirectional Fiber SC Connection + 1
 Bidirectional Fiber LC Connection - PA1170B + PA1171B

HOW TO CONNECT AND DISCONNECT MINI GBIC

Connecting GBIC:

STEP 1



STEP 2



Figure 49 – Connecting GBIC

Disconnecting GBIC:

STEP 1



STEP 2

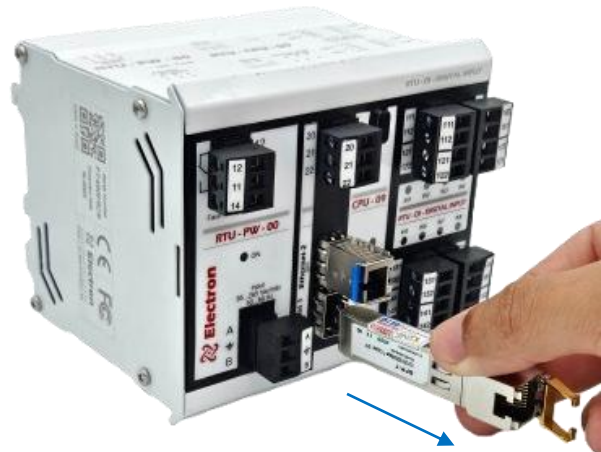

Figure 50 – Disconnecting GBIC

DOWNLOAD AND INSTALLATION OF RTU SOFTWARE BY WINDOWS 10

Follow these steps to download the RTU configuration software:

1) Open your web browser, type in the Electron do Brasil address, and then access the product page and download the RTU configuration software as shown in the figure below.

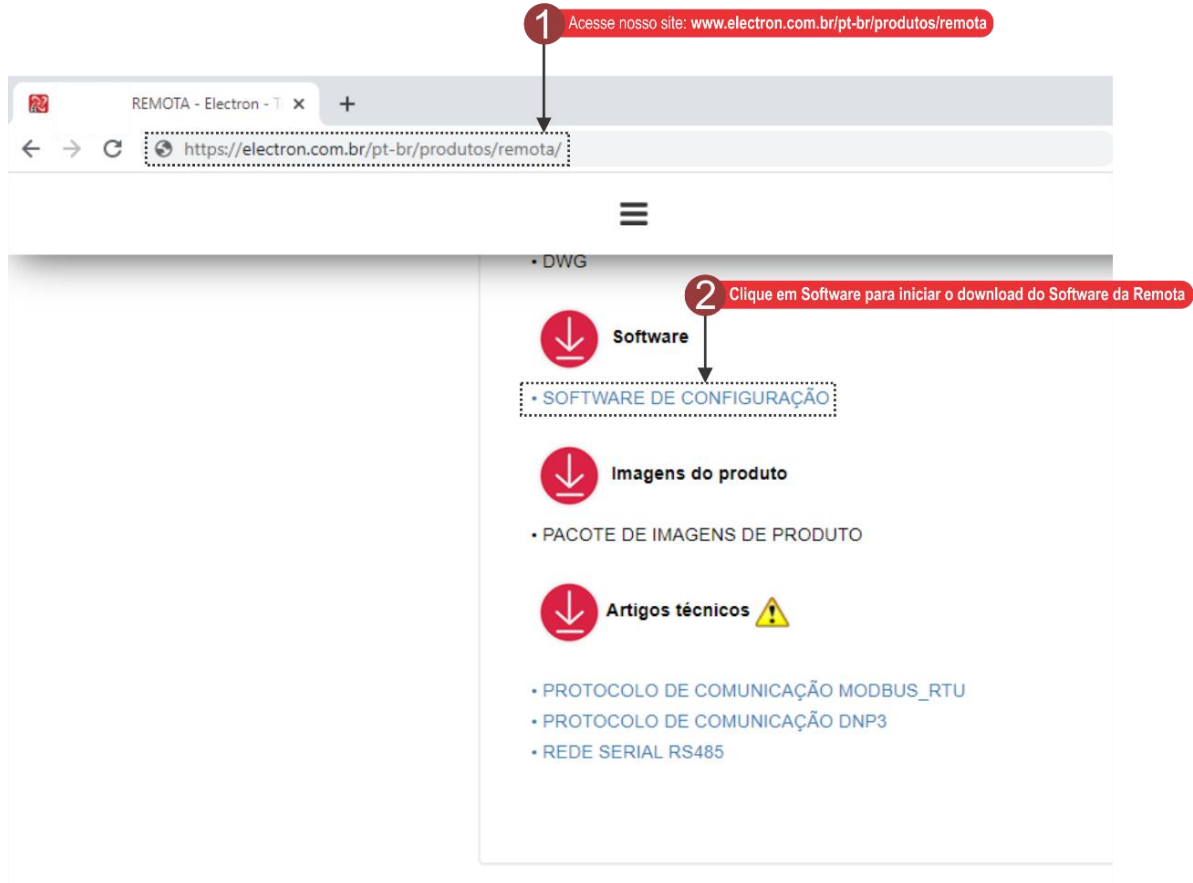

Figure 51 - Screenshot of Electron do Brasil's RTU product page

2) After

downloading the application, run the '**RTU-Cloud.exe**' file.

IMPORTANT: If your browser or your antivirus for a few minutes to complete the download. The same procedure must be repeated when running the file because some antivirus or even Windows Defender block functions of our software.

If you are using Windows 10, the same windows should appear on your computer requiring the appropriate permissions to continue and access our application. Our applications and files are completely safe and free from malicious resources.

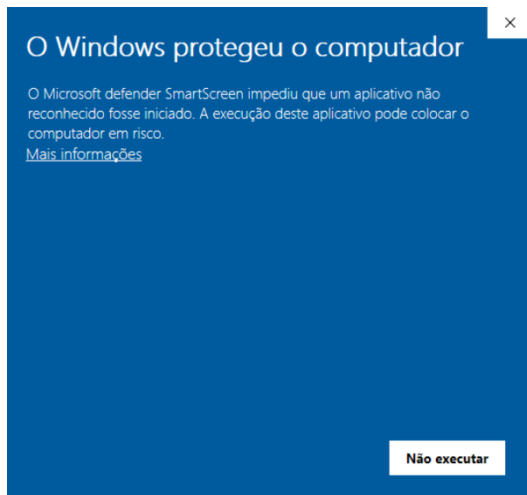

3) If this window has appeared on your computer, click on the underlined option "**More information**" and then, Continue to stage 4.

Figure 52 – Windows Defender – More Information

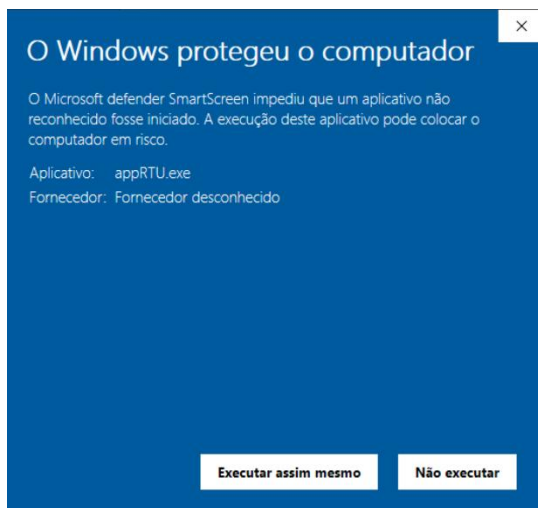

4) Now click on the 'Run Anyway' button allowing the features of our application to be accessed.

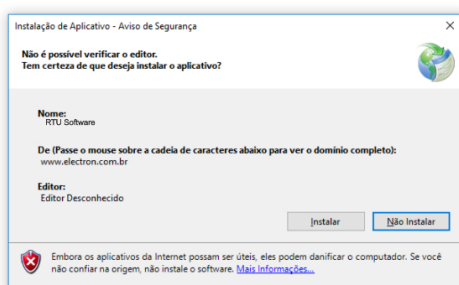
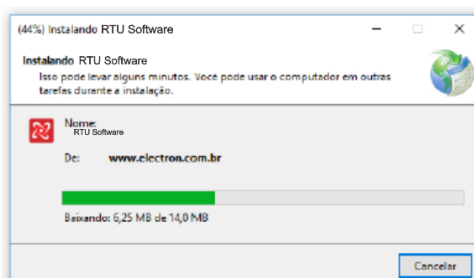

Figure 53 – Windows Defender – Run Anyway

5) In this step, click on the "**Install**" button.



6) Wait for the download to finish finishing.

Figure 54 – Download Status Window

CONFIGURING THE RTU VIA SOFTWARE

When you finish downloading and installing RTU Software, the home screen opens as shown in the image below:



Figure 55 - RTU Configuration Software Splash Screen

Connect your RTU equipment using a micro-B USB cable, after connecting it to your equipment connect the USB end to a computer or notebook so that the software can identify it.

When connecting the equipment, the software will display an Information window with the following message: **"The transmission has been received successfully"**, as shown in the figure below. Click **OK**.

Note that the settings options at the top of the software that were previously unavailable will be available for the configuration of the equipment.

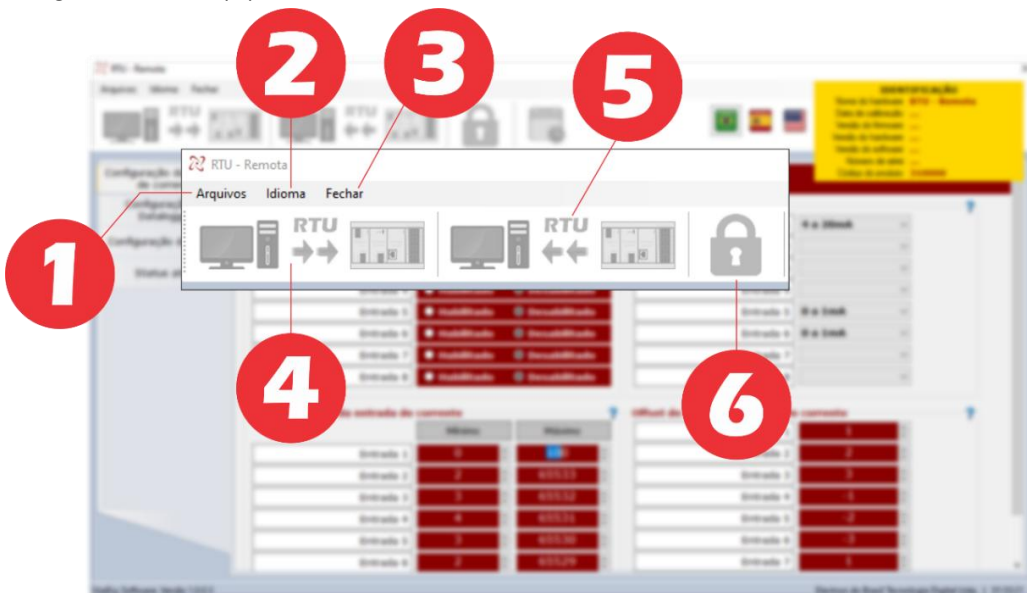

Figure 56 - Highlight of the main tab of the Software

1 – Archives

Open parameters file...

Allows you to open a file of parameters of the RTU equipment in the software.

Save parameters file...

Exports the current parameters of your equipment by creating a file in the format . RTU.

Print the RBM Parameter Values ...

Allows printing with the parameters of the equipment. RBM.

2 – Languages

Portuguese – Standard

Define the software with the Portuguese language.

Spanish

Sets the software to the Spanish language.

English

Sets the software to the English language.

3 – Date or software

Date or software.

4 – Send parameters

Sends parameters from the equipment to the Software.

NOTE: A window will appear asking for the password, by manufacturing default, the password is 0000. If the password entered is incorrect, no parameter will be sent to the Software.

5 – Receive parameters

Receives parameters from the equipment in the Software.

6 – Change access password

Change your passkey to a new passcode. To do this, enter the current password and in the following fields, enter your new password and click on the OK button, as illustrated in the figure below.

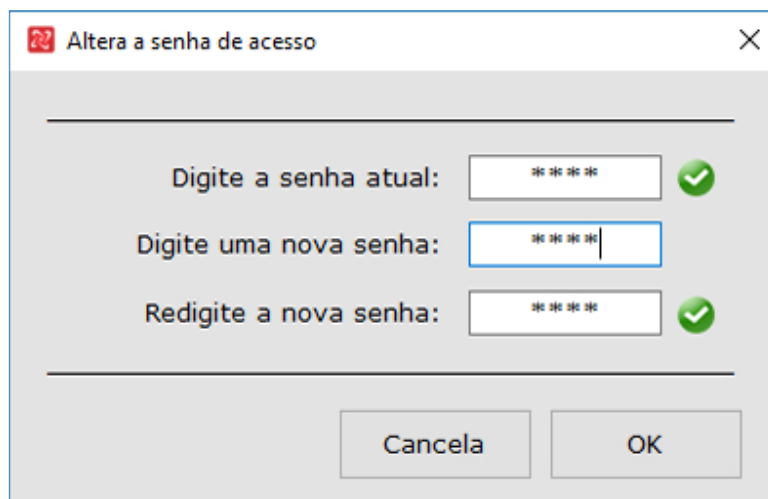

Figure 57 - Password change window for accessing Remota's software



Figure 58 - Screenshot highlighting the enumeration of the settings tabs of the RTU software

7 – Current input configuration

Habilitação da entrada de corrente ?

Entrada 1	<input checked="" type="radio"/> Habilitado	<input type="radio"/> Desabilitado
Entrada 2	<input checked="" type="radio"/> Habilitado	<input type="radio"/> Desabilitado
Entrada 3	<input checked="" type="radio"/> Habilitado	<input type="radio"/> Desabilitado
Entrada 4	<input checked="" type="radio"/> Habilitado	<input type="radio"/> Desabilitado
Entrada 5	<input checked="" type="radio"/> Habilitado	<input type="radio"/> Desabilitado
Entrada 6	<input checked="" type="radio"/> Habilitado	<input type="radio"/> Desabilitado
Entrada 7	<input checked="" type="radio"/> Habilitado	<input type="radio"/> Desabilitado
Entrada 8	<input checked="" type="radio"/> Habilitado	<input type="radio"/> Desabilitado

Figure 59 - Field to enable or disable the desired current input

Enabling Current Input:

ENABLED

In this condition, the selected Power Input will be turned on.

DISABLED The selected Current Input will be turned off.

Tipo de entrada de corrente ?

Entrada 1	0 a 1mA
Entrada 2	0 a 5mA
Entrada 3	0 a 10mA
Entrada 4	0 a 20mA
Entrada 5	4 a 20mA
Entrada 6	
Entrada 7	
Entrada 8	

Figure 60 - Field to Select the Type of Current Input

Current Input Type:

Select the type of current input for each of the eight inputs, namely:

- 0 a 1mA;
- 0 a 5mA;
- 0 a 10mA;
- 0 a 20mA;
- 4 a 20mA;

Faixa de leitura da entrada de corrente ?

	Mínimo	Máximo
Entrada 1	0	500
Entrada 2	0	500
Entrada 3	0	200
Entrada 4	0	200
Entrada 5	0	1000
Entrada 6	0	100
Entrada 7	0	100
Entrada 8	0	100

Figure 61 - Highlight of the Current reading range field

Current input reading range

Select a Minimum and Maximum value for each of the eight inputs according to the parameters of your application's quantity.

8 – Datalogger Configuration

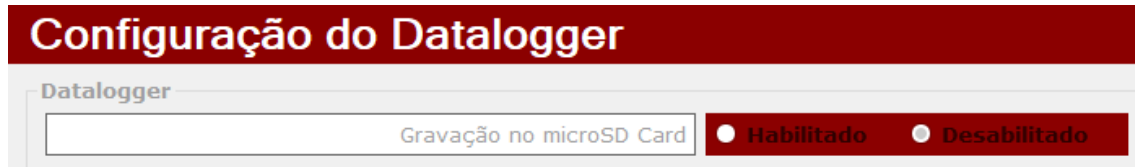

Figure 62 - Datalogger Configuration Highlight

ENABLED

In this condition, the data recording to the SD Card will be performed.

DISABLEDThe condition recording data to the SD Card will be disabled.

9 – RS-485 settings

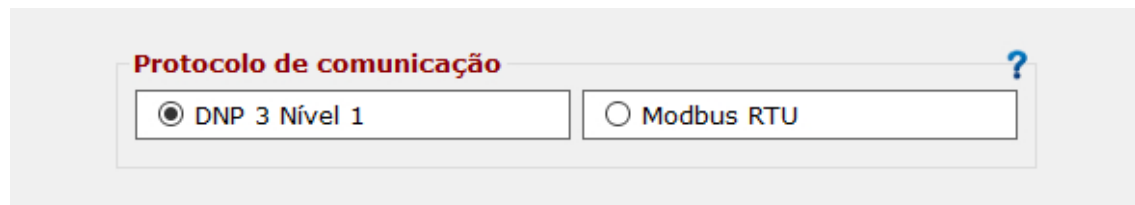

Figure 63 - Highlight of the communication protocol selection field

DNP 3 – Level 1

DNP 3.0 Lv.1 Communication Protocol Selection

Modbus RTU

MODBUS RTU Communication Protocol Selection

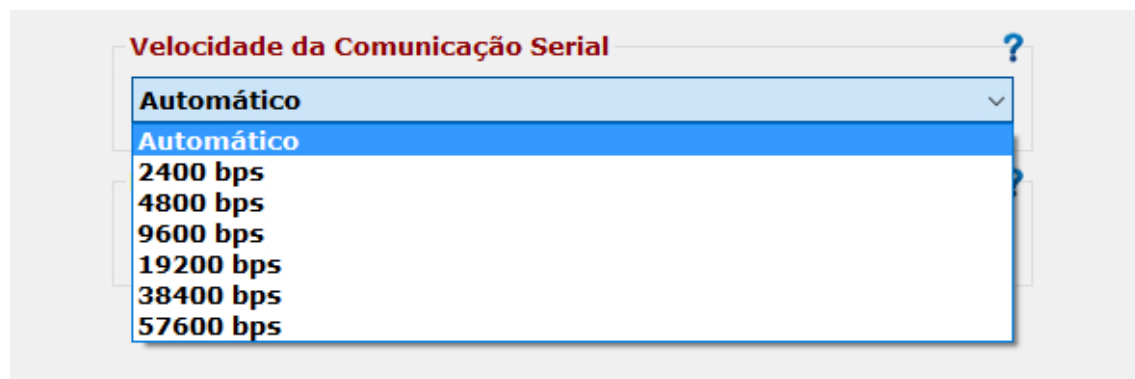

Figure 64 – Highlight of the Serial Communication Speed selection field

Serial Communication Speed

Select the Auto mode that will identify the network speed automatically, or select one of the available values to fix the serial communication speed (2,400 bps, 4,800 bps, 9,600 bps, 19,200 bps, 38,400 bps, or 57,600 bps).

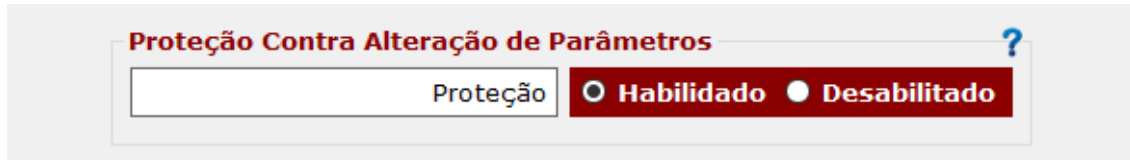

Figure 65 - Highlight of the Parameter Change Protection field

Protection against Parameter Change

To inhibit writing to the register parameters.

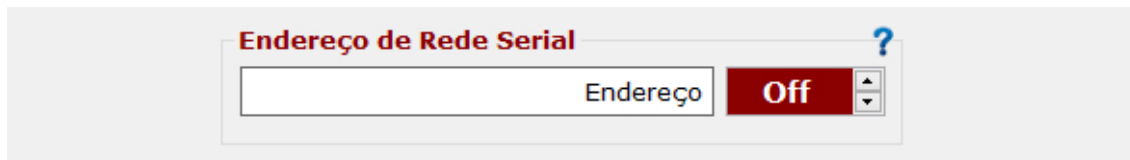

Figure 66 - Serial Network Address Highlight

Protection against Parameter Change

For serial network address configuration, each equipment connected to the RS485 network must have only a single address that is different from the others. So that the supervisor can identify it.

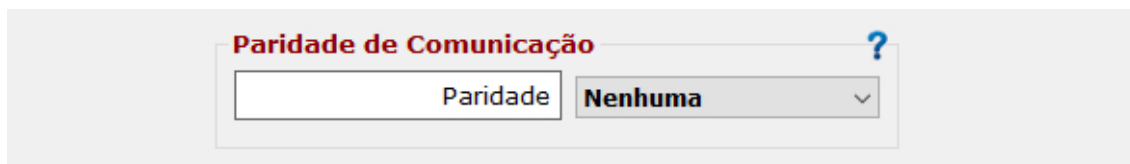

Figure 67 - Highlight of the Parity Selection field

Communication Parity

For parity setting, i.e. the last bit to be transmitted in the message to verify data integrity.



Figure 68 - Highlight of the parity selection field

Password reminder

In case of lost or forgotten password, please contact Electron do Brasil and provide the password reminder.

10 – Status Current

Figure 69 - Highlight of the RTU status field

Run Status

Runs the equipment showing the status of the sensors

Save to File

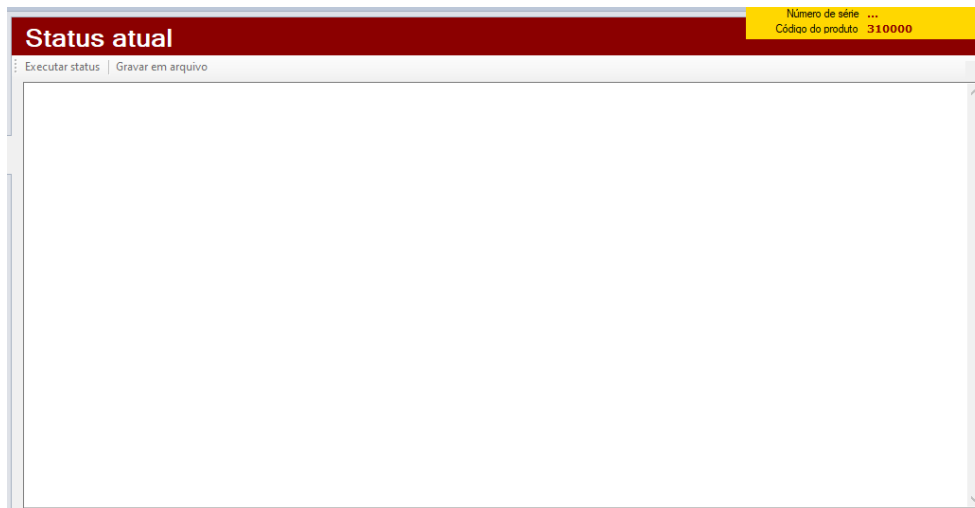
Uploads the current condition of the Relay by generating a . RTU

IMPORTANT RECOMMENDATIONS

Before putting the equipment into operation, check the following recommendations:

1. The sensor as well as the equipment must be grounded, do not use the same point of grounding for the power supply and the sensor, so that there is no difference in potential.
2. Properly grounded sensor and power prevent malfunction or damage in cases of disturbances, surges, and inductions in the equipment.
3. Use in the communication network (Rs485) 120 Ohm resistors at the 2 ends of the line transmission (beginning and end) in order to generate a potential difference necessary for the correct functioning of the communication network.

WARRANTY TERM

REMOTA RTU has a warranty period of two years from the date of sale recorded on the invoice, with coverage for any manufacturing defects that make it unsuitable or unsuitable for the applications for which it is intended.

Disclaimer of Warranty

The warranty does not cover transportation expenses for technical assistance, freight and insurance for shipment of a product with evidence of defect or malfunction.

The following events are also not covered: Natural wear and tear of parts due to continuous and frequent use, damage to the outside caused by falls or improper packaging; attempt to repair/violate a seal with damage caused by people not authorized by Electron do Brasil and in disagreement with the instructions that are part of the technical description.

Loss of Warranty

Product will automatically lose warranty when:

- If the instructions for use and assembly contained in this manual and the installation procedures of the NBR 5410 standard are not observed;
- Subjected to conditions outside the limits specified in the respective technicians;
- Violated or repaired by a person other than the technical team of Electron do Brasil;
- The damage is caused by water or any other liquid;
- Infiltration of water or any other liquid occurs;
- Overload occurs that causes degradation of components and parts of the product;

Use of the Warranty

To enjoy this warranty, the customer must send the product to Electron do Brasil along with a copy of the purchase invoice properly packaged so that there is no damage in transport. For an emergency service, it is recommended to send as much information as possible regarding the defect detected. This will be analyzed and subjected to full functional tests. The costs for sending and receiving the equipment are at the customer's expense.

The analysis of the product and its eventual maintenance will only be carried out by the technical team of Electron do Brasil at its headquarters.