



Intelligent Isolated Transducer

CATALOGUE

INDEX

INDEX.....	2
INTRODUCTION	3
TIIE TECHNICAL DATA.....	3
TYPE TRIALS MET	4
DIMENSIONS	4
LINKAGE AND CURRENT LINKAGE DIAGRAM	4
APPLICATION EXAMPLE.....	5
SPECIFICATION FOR ORDER.....	6

INTRODUCTION

The Electron Smart Isolated Transducer **TIIE** was developed with the aim of:

- 1) Receive resistive signals; voltage and current;
- 2) Convert them into analog (4 to 20 mA or 0 to 10 V) or digital (Modbus RTU and DNP 3 L1) signals;
- 3) Perform alarm relay or trip functions (according to the customer's selection);
- 4) Send the signal via RS485 digital output, via analog output (4 to 20 mA or 0 to 10 V) or display it on a local display (when selected by the customer) or in its own software through the USB port;

The equipment was developed with galvanic isolation between the power, input and output circuits, avoiding any interference in their respective signals. It has LED indication for power, failure, alarm 1 and alarm 2. As an option, this IDE can also be supplied with an OLED display on which there will be an indication of the measured quantity as well as fault and alarm alerts.

Its analog outputs are configurable via UseEasy™ software (available for free download). Relay to identify fault in sensor reading. Up to 2 alarm contacts with programmable timing and hysteresis. It also has a USB port on the front for parameterization and monitoring through the UseEasy™ software.

Its housing, the smallest on the market, is prepared for mounting on a 35 mm DIN rail and its pluggable connector system facilitates installation and maintenance

TIIE TECHNICAL DATA

ELECTRON SMART ISOLATED TRANSDUCER - TIIE	
Operating Voltage	24 to 265 Vdc/Vac;
Operating Temperature	-40 to +85 °C;
Storage Temperature	-50 to .60°C;
Consumption	< 15 W;
USB port	USB Serial;
Box	22.5 x 100 x 113.5 mm in ABS;
Fixation	DIN rail 35 mm;
Serial Communication Port	RS485 (ANSI/TIA/EIA-485-A);
Transmission Mode	Half Duplex;
Communication Protocol	RTU and DNP Modbus 3.0 – L1 (slave);
Auto Baud Rate	2,400 to 57,600 bps;
Electrical voltage output options	0 ... 5V;
	0 ... 10V;
Current output and maximum load options	0 ... 1 mA – 8000 Ω;
	0 ... 5 mA – 1600 Ω;
	0 ... 10 mA – 800 Ω;
	0 ... 20 mA – 400 Ω;
	4 ... 20 mA – 400 Ω;
Maximum Analog Output Error	0.25% of the end of the scale;
Temperature Measurement Input	Sensor RTD;
Temperature Measurement Range	-100 to 850°C;
Sampling	30 ms;
Maximum Measurement Input Error	0.25% of the end of the scale;
Warranty	2 years

Table 1 - Technical data

TYPE TRIALS MET

- Applied Voltage (IEC 60255-5): 2 kV / 60 Hz / 1 min (against ground);
- Voltage Impulse (IEC 60255-5): 1.2/50 μ s / 5 kV / 3 neg and 3 pos / 5 s Interval;
- Immunity to Electrical Transients (IEC60255-4) (IEC60255-6): 2.5 kV / 1.1MHz / 2s, 400 surges/s – 5 cycles;

DIMENSIONS

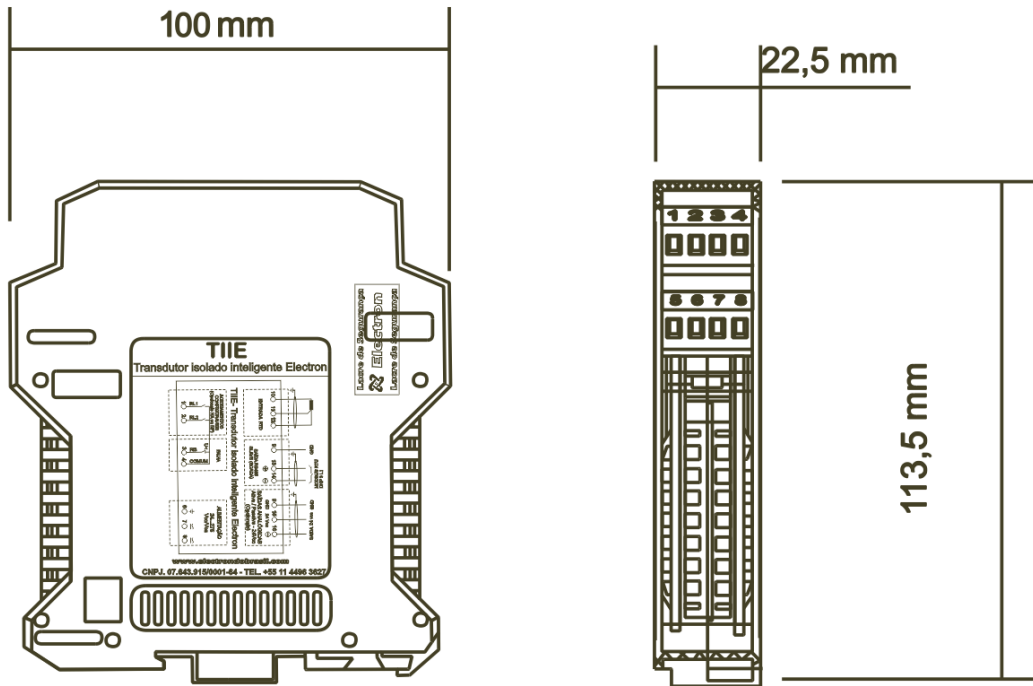

Image 1 - dimensions

LINKAGE AND CURRENT LINKAGE DIAGRAM

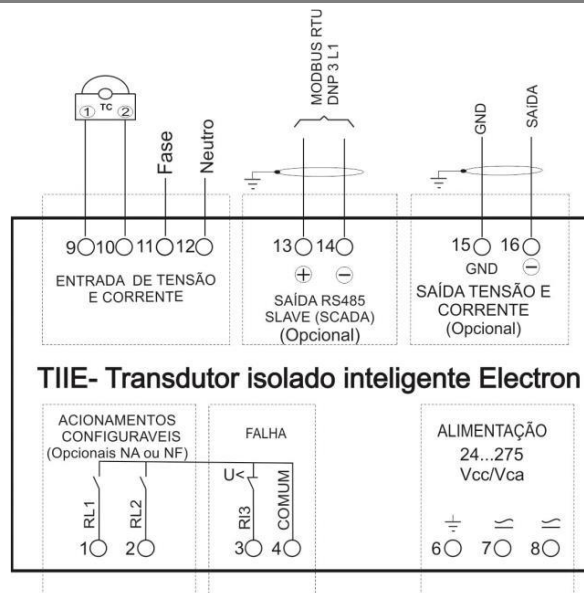

Image 2- Connection diagram

APPLICATION EXAMPLE

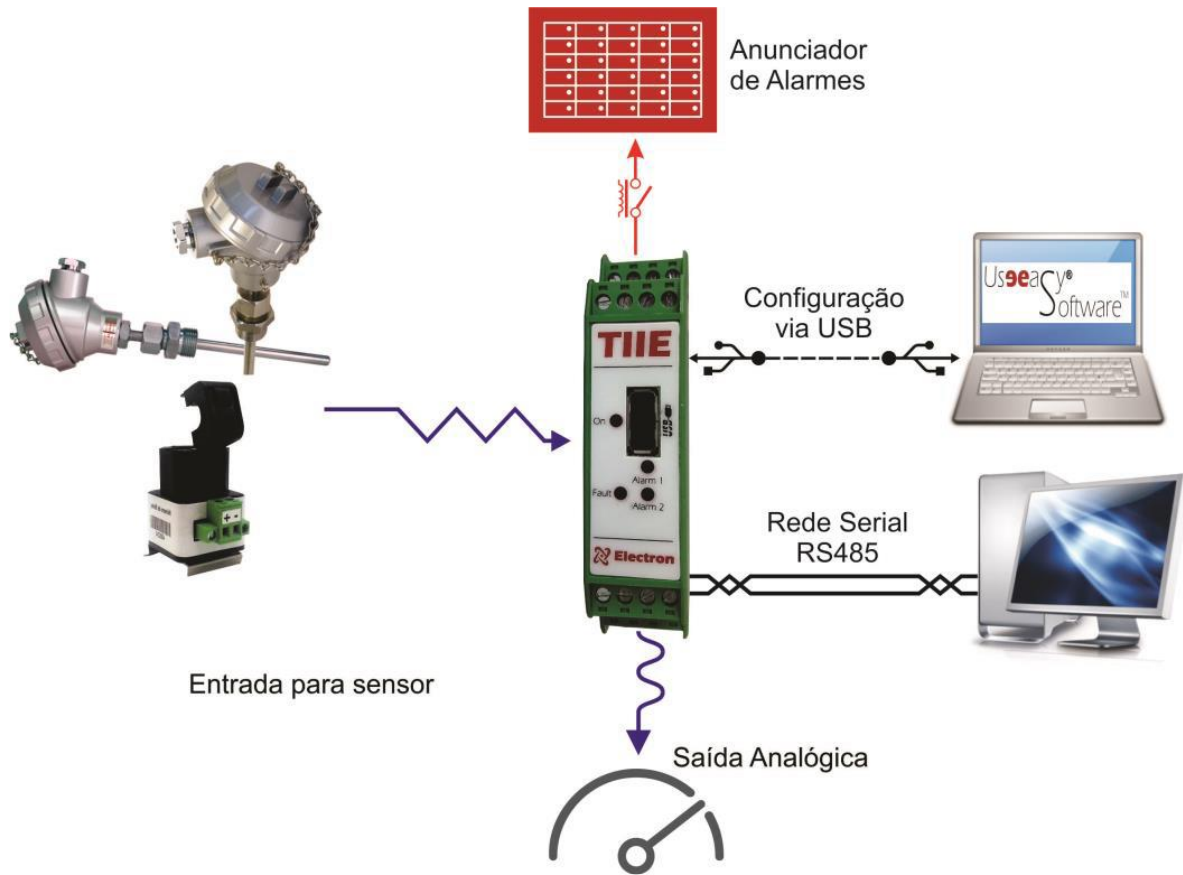

Image 3 – Application example

SPECIFICATION FOR ORDER

