



---

# RTU POWER CONNECT

---

CATALOG

## INDEX

INDEX .....	2
INTRODUCTION .....	3
MAIN FEATURES .....	4
TECHNICAL DATA .....	5
DIMENSIONS.....	6
APPLICATION EXAMPLE.....	6
RTU POWER CONNECT CONNECTION DIAGRAM - 0.....	7
RTU POWER CONNECT CONNECTION DIAGRAM- 1 .....	7
MODULES .....	8
OPTIONAL PURCHASE ACCESSORIES.....	8
SPECIFICATIONS FOR ORDER .....	9
DOWNLOAD PARAMETERIZATION SOFTWARE .....	9
IMPORTANT RECOMMENDATIONS .....	10
WARRANTY TERM.....	10
<i>disclaimer of warranty</i> .....	10
<i>loss of warranty</i> .....	10

**INTRODUCTION**

The **RTU POWER CONNECT** (Remote Terminal Unit) from Electron do Brasil is a microprocessed equipment with high capacity for data acquisition, monitoring, indication, control and supervision. This makes it a robust and versatile solution for various sectors such as:

- **ENERGY**
  - Electrical Substations;
  - Hydroelectric Power Plants;
  - Solar Power Plants;
  - Wind Power Plants;
  - Green Hydrogen Plants (H2 Green);
  - Power Transmission and Distribution Transformers;
  - Protection, Distribution and Control Panels;
- **OIL AND GAS**
  - Fixed Oil Platforms;
  - Self-elevating;
  - Semi-submersible;
  - FPSO;
  - FPSO Mono column;
  - TLWP;
  - Navio Sonda;
- **TRANSPORT**
  - Traffic Control;
  - Railroad Control;
  - Electric Trains and Trams;
- **CONSTRUCTION**
  - Smart Building Management (BMS);
  - Monitoring and Control of Escalators;
  - Air Conditioning Monitoring and Control;
  - Elevator Monitoring and Control;
  - Lighting Monitoring and Control;
- **SANITATION**
  - Monitoring and Control of Reservoir Level;
  - Pump Monitoring and Control;
  - Monitoring and Control of Signals and Sensors;

**RTU POWER CONNECT** offers many advantages in its implementation. The download and use of its Software is free, intuitive and easy to configure. Internet connection to access statuses and parameters via platform (monitrafo.com) mobile application and pairing via Bluetooth.

There are 2 (two) **RTU POWER CONNECT** options, the one that consists of 8 Digital Inputs (DI) and the version without digital input, which provide many possibilities for data acquisition, monitoring and control for various applications.

The **RTU POWER CONNECT** is a compact device (100 x 77 x 98 mm in both versions), built with extruded aluminum and electrostatic paint, providing protection against external chemical agents. The aluminum casing also shields the internal electronics from electromagnetic interference and acts as an excellent thermal dissipator, increasing the longevity of its components. The device can be mounted on a 35mm DIN rail at the bottom of the panel.

**MAIN FEATURES**

- **FEEDING**  
9 to 28 Vdc.
- **USB Type-C INPUT**  
1 USB input for communication with the free use UseEasy™ Parameterization Software.
- **SSU INPUT**  
Optical Interface;  
110bps;  
NBR-14522.
- **LOG**  
Log recording as a function of time and variation of the measured quantity and the variables that will be selected for recording are configurable.
- **NORMAL**  
NBR 14522 (CODI/ABNT).
- **RS-485 SERIAL (SLAVE) OR MASTER**  
1 RS-485 digital input (ANSI/TIA/EIA-485-A) with serial communication protocol selection option:
  - a) Modbus RTU;
  - b) DNP3 level 2;**NOTE:** For use of this master input, Electron do Brasil must be consulted and informed about the details of the desired application.
- **SIM CARD SLOT**  
1 SIM Card Slot - NB-IoT for remote monitoring via IoT using 2G to 5G Service.
- **WIRELESS INTERNET COMMUNICATION**  
Protocols:
  - a) Modbus TCP;
  - b) Modbus RTU;
  - c) MQTT (IoT);
  - d) DNP.
- **RJ-45 INPUT**  
1 RJ-45 connector input for communication via Ethernet TCP/IP with protocols:
  - a) Modbus TCP;
  - b) Modbus RTU;
  - c) MQTT (IoT);
  - d) DNP.
- **Indoor/Outdoor Antenna (NB-IOT)**  
12 dBi  
Frequency: 700MHz – 2.7 GHz
- **Configuration Software (FREE):**  
RTU – UseEasy Software.

## TECHNICAL DATA

RTU POWER CONNECT	
<b>Operating Voltage Range</b>	9 to 28 Vdc
<b>Operating Temperature Range</b>	-40°C to +85°C
<b>Power Consumption</b>	< 15 W
<b>Number of Digital Input</b>	8 DI's (Only for the model with DI)
<b>Communication port with software</b>	USB Type-C connector
<b>Serial communication port</b>	RS485 – 2 wires (ANSI/TIA/EIA-485-A)
<b>Communication protocol</b>	Modbus RTU, Modbus TCP (WI-FI), DNP3 L1, DNP3 L1 – TCP (WI-FI) and MQTT TLS/SSL – (WIFI), NBR-14522 (CODI/ABNT).
<b>Auto Baud Rate</b>	1,200 to 57,600bps
<b>WI-FI</b>	Standards B/G/N/E/I
	WPA/WPA2/WPA-Enterprise
	Up to 150Mbps data rate
	Up to 21dBm Transmit Power
<b>NB-IOT Antenna</b>	12 dBi
	Frequency 700MHz – 2.7 GHz
	Magnetic Attachment (External Antenna)
	External antenna – specify footage
<b>RJ-45 INPUT</b>	1 RJ-45 connector input for communication via Ethernet TCP/IP with Modbus TCP protocols; Modbus RTU, DNP
<b>SIM CARD SLOT</b>	1 SIM Card Slot - For remote monitoring via NBloT network.
<b>SSU INPUT</b>	Optical Interface
	Speed – 110bps
	Protocol NBR-14522
<b>Dimensions Box (DIN Standard) IEC 61554</b>	100 x 98 x 77 mm
<b>Hardware Packaging</b>	Aluminium
<b>Fixation</b>	DIN standard for 35mm rail
<b>Protection</b>	IP 20

Table 1 – Technical data

**DIMENSIONS**

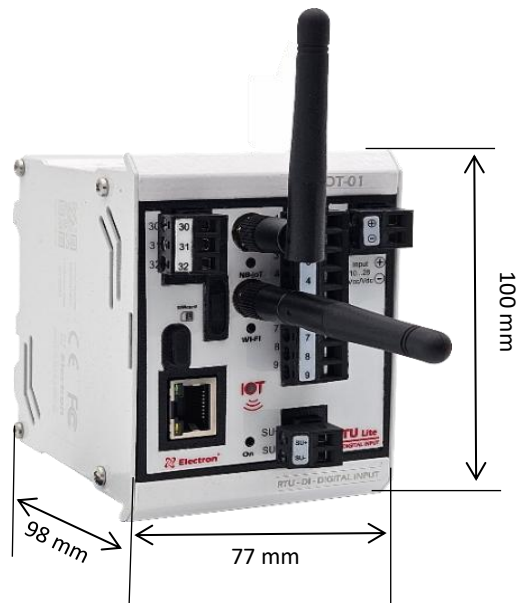

Image 1 – dimensions

**APPLICATION EXAMPLE**

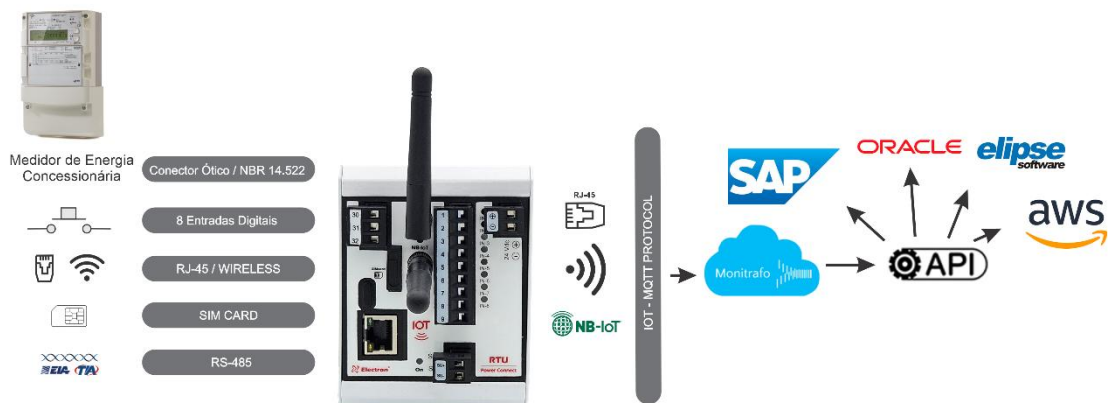

Image 2 – Application examples

RTU POWER CONNECT CONNECTION DIAGRAM - 0

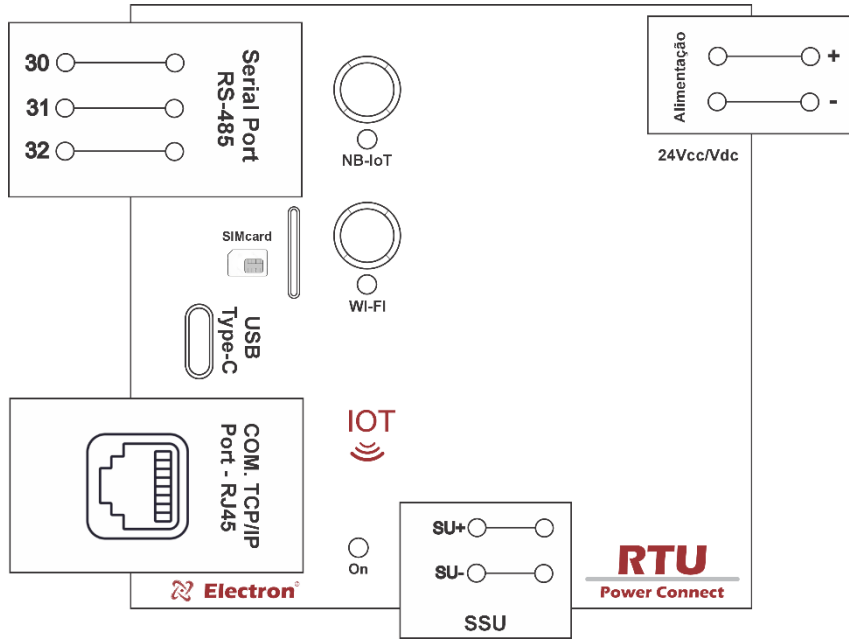

Image 3 – RTU Power Connect Diagram - 0

RTU POWER CONNECT CONNECTION DIAGRAM- 1

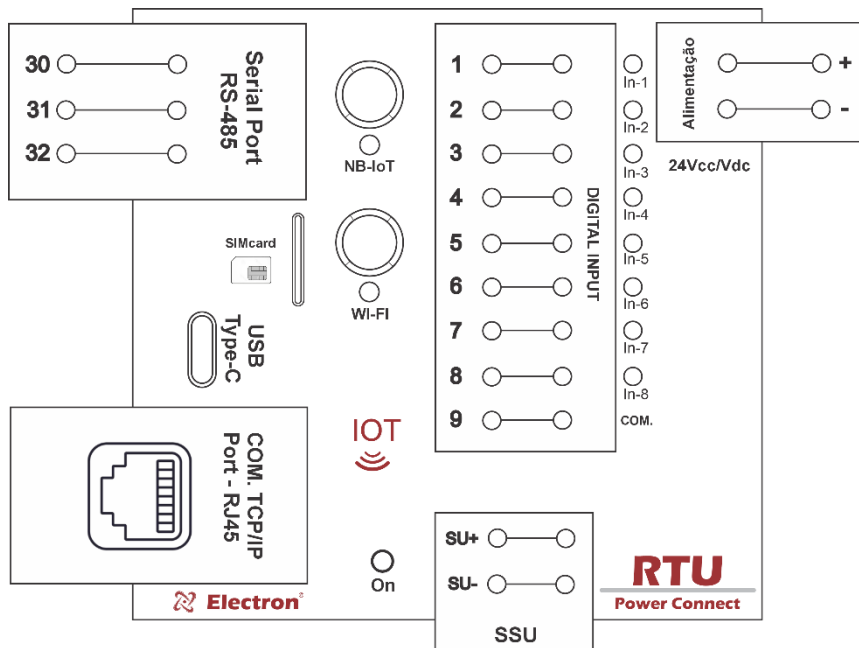

Image 4 – RTU Power Connect Diagram - 1

MODULES

Core Module		
Abbreviation	Function	Description
RTU POWER CONNECT	RS-485 SERIAL (SLAVE)	RS-485 digital input (ANSI/TIA/EIA-485-A) with option to select serial communication protocol Modbus RTU, Modbus TCP and DNP3 level 2, NBR-14522, for remote access of all monitored parameters and variables.
	USB INPUT	1 USB Type-C input for communication with the free-to-use UseEasy TM Parameterization Software
	WIRELESS INTERNET COMMUNICATION	Protocols: Modbus TCP – WIFI; Modbus RTU – WIFI and MQTT for IOT monitoring.
	SIM CARD SLOT	1 SIM Card Slot - NBloT (2G to 5G), for remote monitoring via IoT using SCADA systems based on MQTT protocol.
	RJ-45 INPUT	1 RJ-45 connector input for communication via Ethernet TCP/IP with Modbus TCP protocols; Modbus RTU and MQTT for remote access of all monitored parameters and variables.
	DI INPUT	8 DI's. (Only for the model with DI)
	SSU INPUT	NBR-14522 standard communication gateway (CODI/ABNT) via SSU

Table 2 – Module data

OPTIONAL PURCHASE ACCESSORIES

- Internal Antenna – For NB-IoT and for Wi-Fi
- External Antenna – For NB-IoT and for Wi-Fi



Image 5 – Magnetic External Antenna

## SPECIFICATIONS FOR ORDER

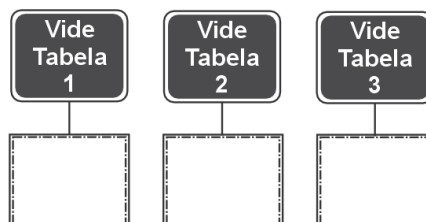
**RTU POWER CONNECT -**

**Table 1 - DIGITAL INPUT (DI)**

Code	Description
0	No Digital Input (0)
1	With Digital Input (8 DI)

**Table 2 - ANTENNAS**

Code	Description
0	No Antennas
1	With Internal Antennas
2	With external antennas

**Table 3 - NB-IOT NETWORK (Internet Connection)**

Code	Description
0	No NB-IOT Network
1	With NB-IOT Network

## DOWNLOAD PARAMETERIZATION SOFTWARE

- [https://www.electron.com.br/software/oficial/rtulite\\_useeasy/setup.exe](https://www.electron.com.br/software/oficial/rtulite_useeasy/setup.exe)

## IMPORTANT RECOMMENDATIONS

**Before putting the equipment into operation, check the following recommendations:**

**Device Compatibility:** Make sure that the devices you want to connect are compatible with the RS485 standard. This standard is typically used in industrial environments, and is ideal for long-distance and multi-drop communications, where multiple devices share the same communication line.

**Verification of Communication Parameters:** Both the connected devices and the converter must be configured with the same communication parameters (baud rate, parity, stop bits, etc.) to avoid errors in data transmission.

**Transmission Distance:** RS485 supports communications up to 1,200 meters, but for longer distances, or in environments with a lot of interference, it is recommended to use high-quality, shielded, and properly grounded cables.

**Use of Termination Resistors:** In long-distance RS485 communications, it is important to install termination resistors (usually 120 ohms) at the ends of the bus to avoid signal reflections that could hinder communication.

**Electrical Insulation:** Consider using electrically insulated converters, especially in industrial settings, to protect equipment from electromagnetic interference and voltage surges.

**Correct Polarity:** RS485 is differential, which means there is a pair of wires for the positive and negative signal. Make sure to properly connect the A(+) and B(-) to avoid signal reversal.

## WARRANTY TERM

The RTU **POWER CONNECT** Electron has a warranty period of two years from the date of sale stated on the invoice, with coverage for any manufacturing defects that make it unsuitable or unsuitable for the applications it is intended for.

### Disclaimer of Warranty

The warranty does not cover transportation expenses for technical assistance, freight and insurance for shipment of a product with evidence of defect or malfunction. The following events are also not covered: Natural wear and tear of parts due to continuous and frequent use, damage to the outside caused by falls or improper packaging; attempt to repair/break a seal with damage caused by persons not authorized by Electron and in disagreement with the instructions that are part of the technical description.

### Loss of Warranty

The product will automatically lose its warranty when:

- The instructions for use and assembly contained in this manual and the installation procedures contained in the NBR 5410 Standard are not observed;
- Subjected to conditions outside the limits specified in the respective technical descriptions;
- Violated or repaired by a person other than Electron's technical team;
- The damage is caused by a fall or impact;
- Infiltration of water or any other liquid occurs;
- Overload occurs that causes degradation of the components and parts of the product.

### How to use the warranty

To enjoy this warranty, the customer must send the product to Electron along with a copy of the purchase invoice properly packaged so that there is no damage in transport. For an emergency service, it is recommended to send as much information as possible, regarding the defect detected. This will be analyzed and subjected to full functional tests. The analysis of the product and its eventual maintenance will only be carried out by the technical team at the headquarters of Electron do Brasil.